

RTsensor

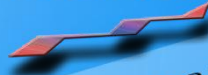

Material is limited, Creation is infinite.

www.RTsensor.com



NTC. PTC. VDR. FUSE

RELIABLE PARTNER FOR YOUR DREAM TECHNOLOGY

About RTsensor

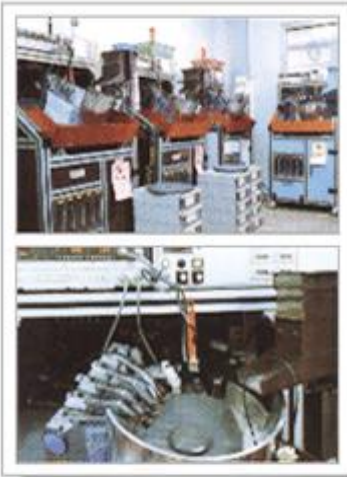

RTsensor was founded by a group of enthusiastic technicians and sales force who have abundant of experience in thermal products and highly motivated to service customers.

Our goal in pursuing the best and perfect have made us in continues progress. And striving for professional thermal product supplier with customer-oriented and service-minded has made us become a staunch supplier.

Is set research and development, manufacturing as one of the high-tech enterprises, the company specializing in the NTC thermistor, NTC temperature sensor, research, development, production and sales. The company USES the advanced technology, innovation of management idea and mechanism, effectively ensure the product performance is stable, reliable, the conventional performance indexes have reached advanced level of similar products at home and abroad.

At present main products are: NTC temperature sensor, glass encapsulation type NTC thermistor series, SMD NTC thermistor series, high precision AT type thermistor (epoxy encapsulation). Widely used in household appliances (heat pump, air conditioners, refrigerators, electric heaters, electric kettles, washing machines, microwave oven, electric water heater, solar water heaters, water dispenser, rice cooker, induction cooker, bread machine, dishwasher, weather forecasting, etc.), industrial equipment (wet machine, boiler, automatic control equipment, instruments and meters, etc.), automotive, medical equipment, computer, energy-saving lamps, power panel, energy-saving power supply, communications equipment high, medium and low temperature humidity field.

Companies adhere to "quality first, users first"; "First-class quality, first-class service"; "Meager profit but high turnover, customer satisfaction" business purposes, the careful manufacture excellent quality, advanced technology, reasonable price products. The company warmly welcome friends both at home and abroad to negotiate business, enhance friendship, create brilliant.

CONTENTS

NTC Thermistor Sensors	*****	5 - 24PG
Automobile Water Temperature Sensors,Chip	*****	25 - 26PG
NTC Chip Thermistor	*****	27 - 29PG
NTC Small Size Thermistor Series	*****	30 - 34PG
NTC Power Thermistor	*****	35 - 41PG
Metal Oxide Varistors	*****	42 - 53PG
PTC Thermistor Sensor	*****	54 - 55PG
PTC Thermistor	*****	56 - 59PG
PTC Thermistors as Limit Temperature Sensor	*****	60 - 63PG
Silicon Temperature Sensors	*****	64 - 65PG

SENSORS INDEX

NTC THERMISTOR

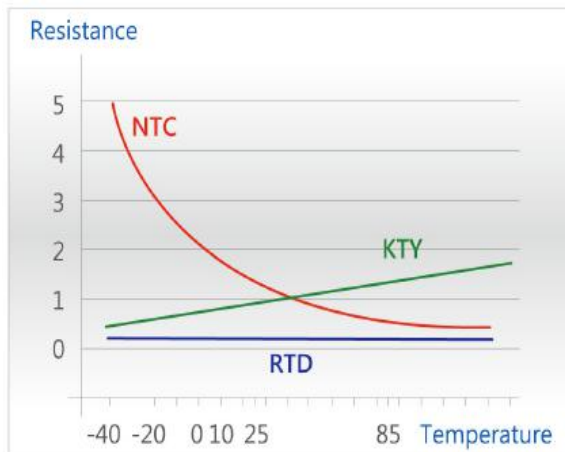

Thermistor is thermally sensitive resistor whose main function is to exhibit a change in electrical resistance with environmental temperature.

Especially, NTC(Negative Temperature Coefficient) thermistor shows the decrease of electric resistance with temperature increase. With high sensitivity and low price, NTC thermistor has variety of application fields such as home electronics, automobile, telecommunication, computer, medical field and other industrial usage.

Zero-power resistance (R_T)

The zero-power resistance is the value of a resistance when measured at a specified temperature, under conditions such that the change in resistance due to the internal generation of heat is negligible with respect to the total error of measurement.

B - Value

An index of the thermal sensitivity expressed by the formula:

$$\beta_{T_a/T_0} = \frac{\ln(R_{T_a}/R_{T_0})}{\frac{1}{T_a} - \frac{1}{T_0}}$$

$$T(K) = 273.15 + T(^{\circ}C)$$

Where

B: constant in Kelvins(K)

R₀: resistance in ohms(Ω) at temperature T₀

R_a: resistance in ohms(Ω) at temperature T_a

The value given above for T₀ and T_a are the preferred values. When the detail specification prescribes that the B-value shall be measured at other temperatures, the specified value (in Kelvins) shall be used for T₀ and T_a in place of the preferred values.

Dissipation constant (δ)

The dissipation constant is the quotient (in W/K), at a specified ambient temperature in specified medium of a change in power dissipation in a thermistor to the resultant body temperature change.

$$\delta = P / (T_2 - T_1)$$

where P, T₂, and T₁ are the dissipated power, thermistor temperature, and ambient temperature respectively.

Response time / Thermal time constant (τ)

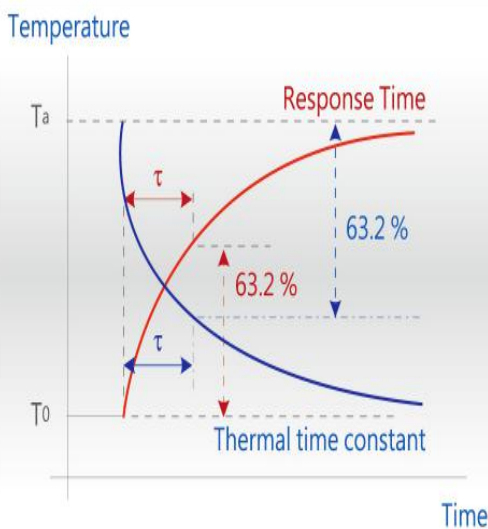

The time (in s) means the time necessary for an unloaded thermistor to vary its temperature by 63.2% of the difference between its thmperature and the ambient temperature. The values of T, specified in this article, is determined in oil at an ambient temperature of 25°C.

Code	Rate of change (%) for T ⁰ -T ^a
τ	63.2
2 τ	86.5
3 τ	95.0
4 τ	98.2
5 τ	99.4
6 τ	99.8
7 τ	99.9

Maximum power rating

The power rating is the maximum power for a continuous load at the rated temperature. For parts in this catalog, the value is calculated from the following using Ta°C as the ambient temperature.

$$P_{\max.} = \delta (T_{\max.} - T_a)$$

How To Measure NTC Thermistors

The published RT-Values are measured at the temperature T .

The published B-Value at 25 °C is the result of the measurement at 25 °C and that at 85 °C. Hence, these values should be used when checking.

The following general precautions have to be taken when measuring NTC thermistors:

- .∴ Never measure thermistors in air; this is quite inaccurate and gives deviations of 1 or 2K. For measurements at room temperature or below, use petrol or some other non-conductive and non-aggressive fluid. For higher temperatures use oil, preferably silicon oil.
- .∴ Use a thermobath with an accuracy of better than 0.1 °C. Even if the fluid is well stirred, there is still a temperature gradient in the fluid. Measure the temperature as close as possible to the NTC.
- .∴ After placing the NTC in the thermobath, wait until temperature equilibrium between the NTC and the fluid is obtained. For some types this may take more than 1 minute.
- .∴ Keep the measuring voltage as low as possible, otherwise the NTC will be heated by the measuring current.

Miniature NTC thermistors are especially sensitive in this respect. Measuring voltages of less than 0.5V are recommended.

- .∴ For high temperature measurements it is recommended that stem correction be applied to the thermometer reading.

NTC Thermistor Sensors

The Temperature sensor is assembled one with various parts and thermistor devices according to the required applications. Its electric characteristics are the same as those of thermistor devices. Variable type of sensor can be utilized for detecting or controlling temperature because its operating temperature range is wide from -50 to +300C. Standard temperature sensor is available in accordance with the applications such as measurements of liquid, atmosphere and surface temperature.

NTC Sensors Coding System



Product No.: NSA*

Description:

- ◆ High stability, high accuracy and high reliability.
- ◆ Provide a flexible design of any kind of sensor.
- ◆ Resistance at 25°C: 100Ω ~ 500K Ω.
- ◆ Resistance tolerance: ±1%, ±2%, ±3%, ±5%

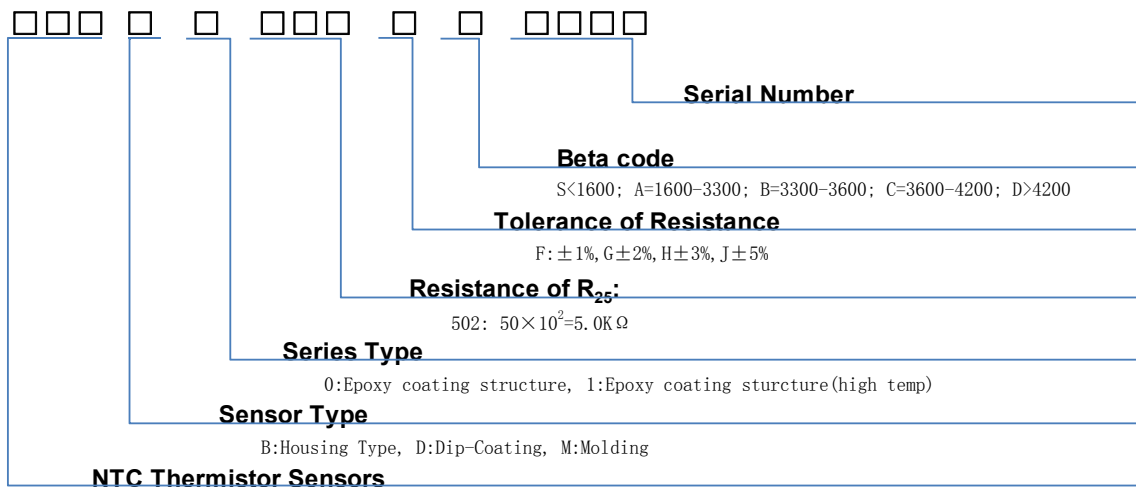

NSA

APPLICATION -- Air-Conditioner

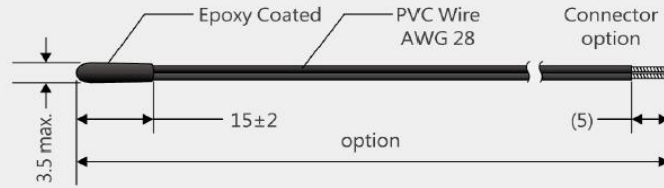

Application :
 Air conditioner
 Operating temp. range :
 -30~+100°C
 Dissipation constant :
 Approx. 2.3mW/°C
 Thermal time constant :
 Approx. 5.5 sec
 Withstand voltage :
 1000V AC for 1 min

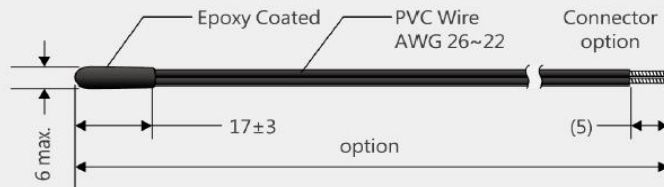

Application :
 Air conditioner
 Operating temp. range :
 -30~+100°C
 Dissipation constant :
 Approx. 2.5mW/°C
 Thermal time constant :
 Approx. 8 sec
 Withstand voltage :
 1500V AC for 1 min

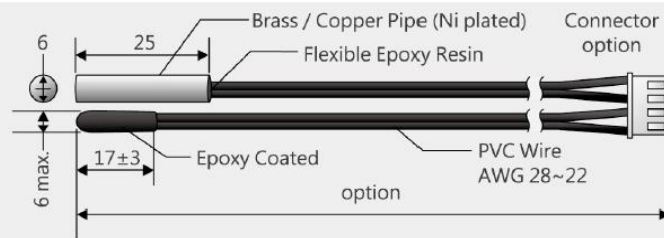

Application :
 Air conditioner
 Operating temp. range :
 -30~+100°C
 Dissipation constant :
 Approx. 2.5mW/°C
 Thermal time constant :
 Approx. 8 sec
 Withstand voltage :
 1500V AC for 1 min

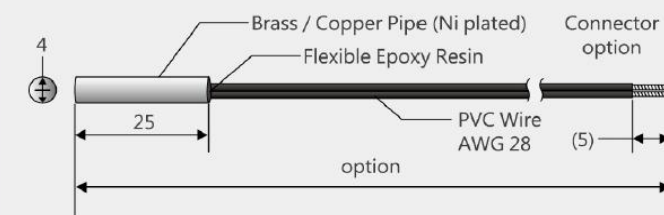

Application :
 Air conditioner, Heat Exchanger
 Operating temp. range :
 -30~+100°C
 Dissipation constant :
 Approx. 2.5mW/°C
 Thermal time constant :
 Approx. 6 sec
 Withstand voltage :
 1500V AC for 1 min

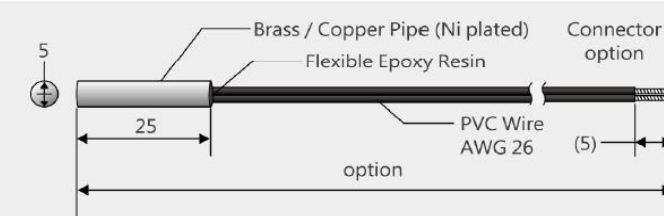

Application :
 Air conditioner, Heat Exchanger
 Operating temp. range :
 -30~+100°C
 Dissipation constant :
 Approx. 3mW/°C
 Thermal time constant :
 Approx. 15 sec
 Withstand voltage :
 1800V AC for 1 min

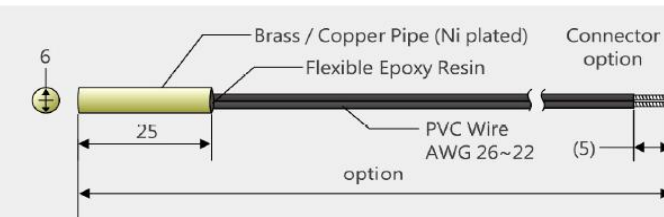

Application :
 Air conditioner, Heat Exchanger
 Operating temp. range :
 -30~+100°C
 Dissipation constant :
 Approx. 3mW/°C
 Thermal time constant :
 Approx. 15 sec
 Withstand voltage :
 1800V AC for 1 min

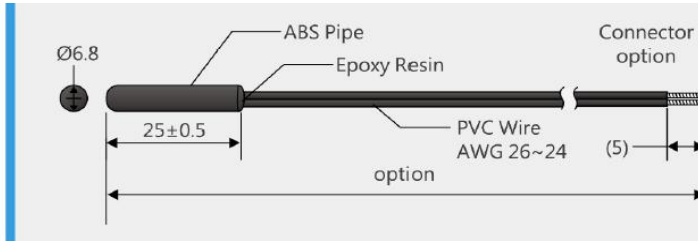

Application :	Air conditioner
Operating temp. range :	-40~+80°C
Dissipation constant :	Approx. 3mW/°C
Thermal time constant :	Approx. 25 sec
Withstand voltage :	1800V AC for 1 min

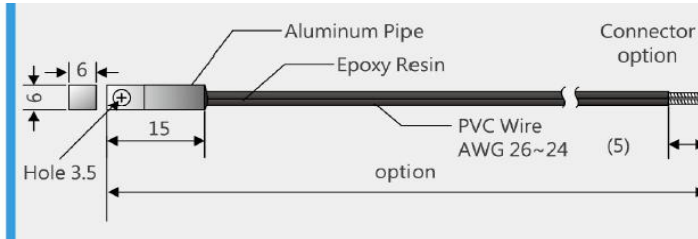

Application :	Air conditioner
Operating temp. range :	-30~+120°C
Dissipation constant :	Approx. 3mW/°C
Thermal time constant :	Approx. 16 sec
Withstand voltage :	1800V AC for 1 min

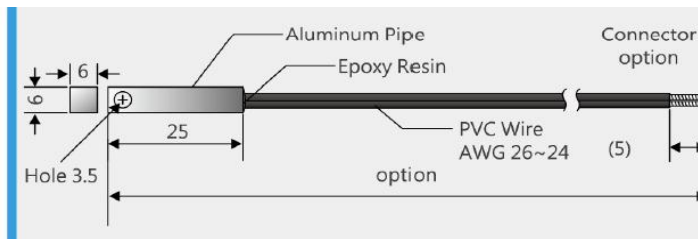

Application :	Air conditioner
Operating temp. range :	-30~+120°C
Dissipation constant :	Approx. 3mW/°C
Thermal time constant :	Approx. 16 sec
Withstand voltage :	1800V AC for 1 min

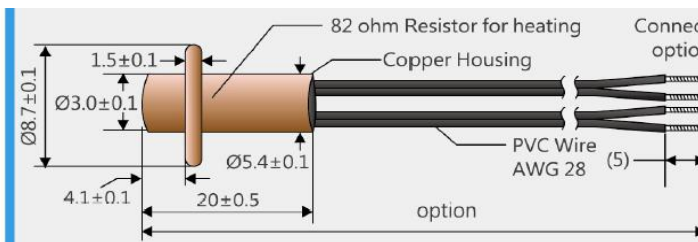

Application :	Water box of Air Conditioner
Operating temp. range :	-30~+80°C
Dissipation constant :	Approx. 3mW/°C
Thermal time constant :	Approx. 10 sec
Withstand voltage :	600V AC for 1 min

Besides The Above Standard Characteristic Product, We Have Some Special Types And Can Provide The Flexible Design According To Your Needs As Well. Please inquire to our sales people for other spec.

APPLICATION -- Refrigerator / Chiller

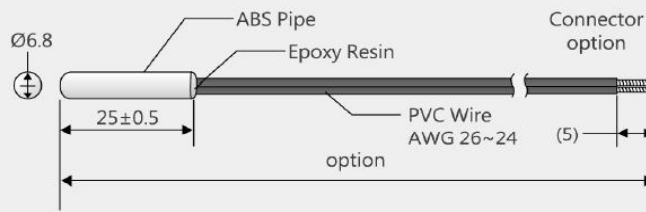

Application :	Refrigerator
Operating temp. range :	-40~+80°C
Dissipation constant :	Approx. 3mW/°C
Thermal time constant :	Approx. 25 sec
Withstand voltage :	1800V AC for 1 min

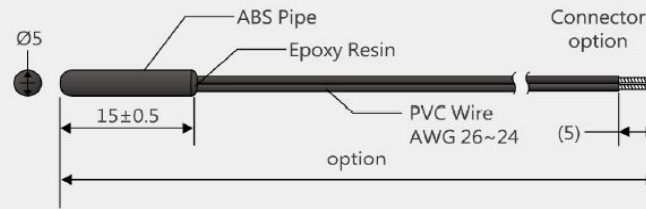

Application :	Refrigerator
Operating temp. range :	-40~+80°C
Dissipation constant :	Approx. 3mW/°C
Thermal time constant :	Approx. 25 sec
Withstand voltage :	1800V AC for 1 min

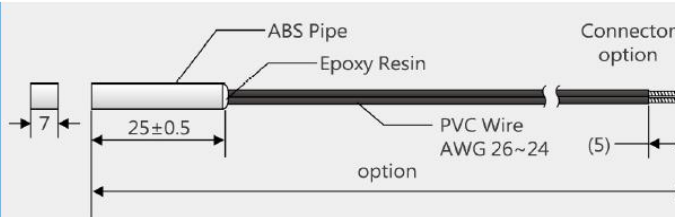

Application :	Refrigerator
Operating temp. range :	-40~+80°C
Dissipation constant :	Approx. 3mW/°C
Thermal time constant :	Approx. 25 sec
Withstand voltage :	1800V AC for 1 min

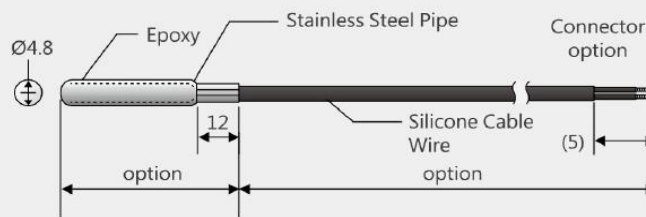

Application :	Refrigerator
Operating temp. range :	-40~+80°C
Dissipation constant :	Approx. 3mW/°C
Thermal time constant :	Approx. 25 sec
Withstand voltage :	1800V AC for 1 min

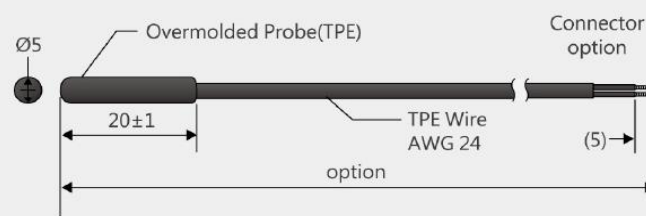

Application :	Refrigerator
Operating temp. range :	-40~+80°C
Dissipation constant :	Approx. 3mW/°C
Thermal time constant :	Approx. 35 sec
Withstand voltage :	1800V AC for 1 min

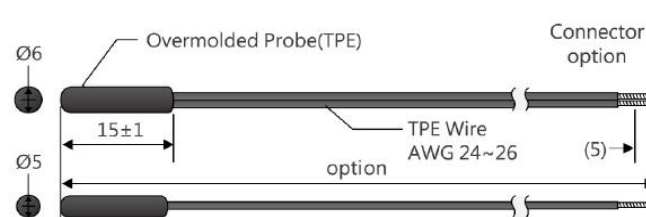

Application :	Refrigerator
Operating temp. range :	-50~+125°C
Dissipation constant :	Approx. 2mW/°C
Thermal time constant :	Approx. 35 sec
Withstand voltage :	1800V AC for 1 min

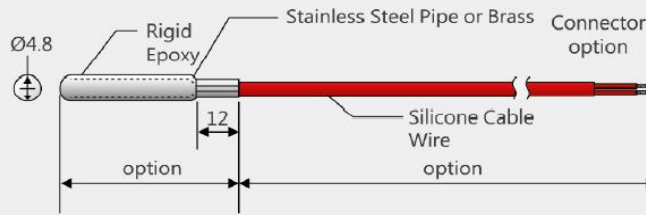

Application :	Refrigerator
Operating temp. range :	-30~+120°C
Dissipation constant :	Approx. 2.3mW/°C
Thermal time constant :	Approx. 10 sec
Withstand voltage :	1000V AC for 1 min

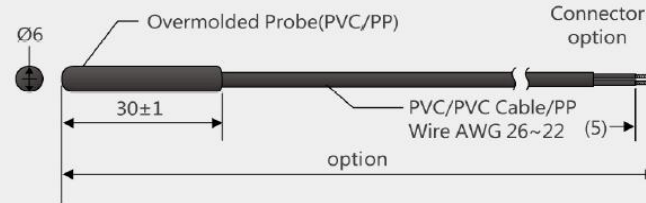

Application :	Refrigerator
Operating temp. range :	-50~+105°C
Dissipation constant :	Approx. 2mW/°C
Thermal time constant :	Approx. 35 sec
Withstand voltage :	1800V AC for 1 min

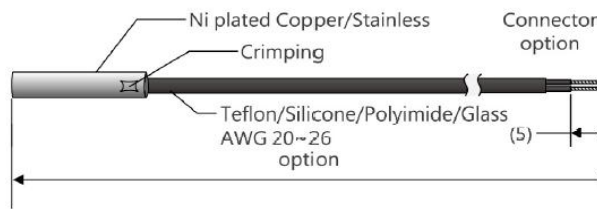

Application :	Refrigerator
Operating temp. range :	-60~+80°C
Dissipation constant :	Approx. 3mW/°C
Thermal time constant :	Approx. 20 sec
Withstand voltage :	1800V AC for 1 min

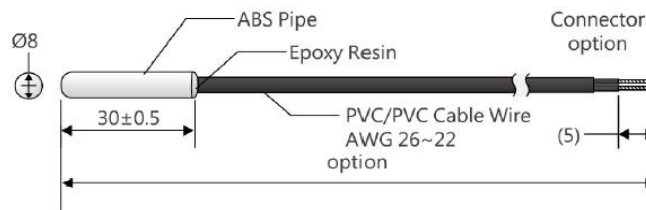

Application :	Refrigerator
Operating temp. range :	-40~+80°C
Dissipation constant :	Approx. 3mW/°C
Thermal time constant :	Approx. 25 sec
Withstand voltage :	1800V AC for 1 min

Besides The Above Standard Characteristic Product, We Have Some Special Types And Can Provide The Flexible Design According To Your Needs As Well. Please inquire to our sales people for other spec.

APPLICATION -- Dehumidifier

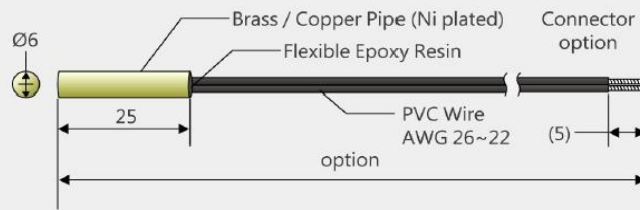

Application :
Dehumidifier, Heat Exchanger
Operating temp. range :
-30~+100°C
Dissipation constant :
Approx. 3mW/°C
Thermal time constant :
Approx. 15 sec
Withstand voltage :
1800V AC for 1 min

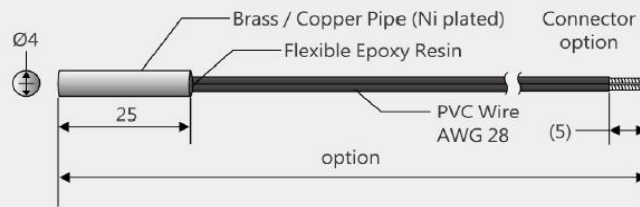

Application :
Dehumidifier, Heat Exchanger
Operating temp. range :
-30~+100°C
Dissipation constant :
Approx. 2.5mW/°C
Thermal time constant :
Approx. 8 sec
Withstand voltage :
1500V AC for 1 min

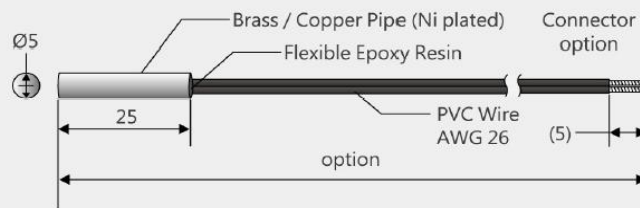

Application :
Dehumidifier, Heat Exchanger
Operating temp. range :
-30~+100°C
Dissipation constant :
Approx. 3mW/°C
Thermal time constant :
Approx. 15 sec
Withstand voltage :
1800V AC for 1 min

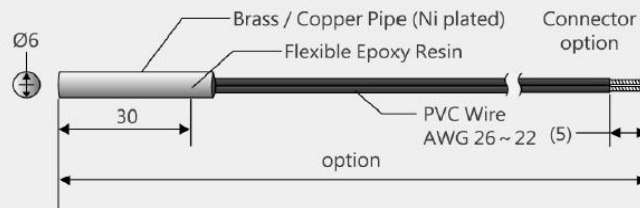

Application :
Dehumidifier, Heat Exchanger
Operating temp. range :
-30~+100°C
Dissipation constant :
Approx. 3mW/°C
Thermal time constant :
Approx. 15 sec
Withstand voltage :
1800V AC for 1 min

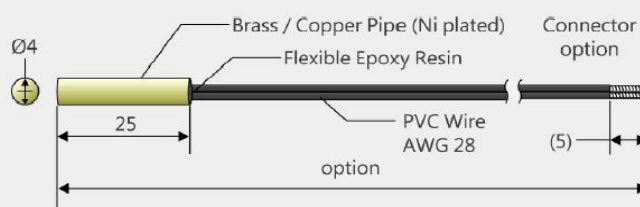

Application :
Dehumidifier, Heat Exchanger
Operating temp. range :
-30~+100°C
Dissipation constant :
Approx. 3mW/°C
Thermal time constant :
Approx. 15 sec
Withstand voltage :
1800V AC for 1 min

Besides The Above Standard Characteristic Product, We Have Some Special Types And Can Provide The Flexible Design According To Your Needs As Well. Please inquire to our sales people for other spec.

APPLICATION -- Coffee maker & Boiler

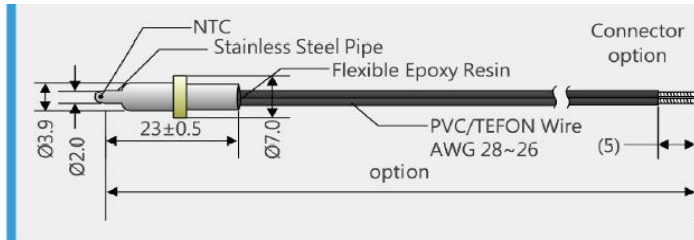

Application :
Boiler , Hot Water Supplier
Operating temp. range :
-30~+120°C
Dissipation constant :
Approx. 2mW/°C
Thermal time constant :
Approx. 1 sec
Withstand voltage :
600V AC for 1 min

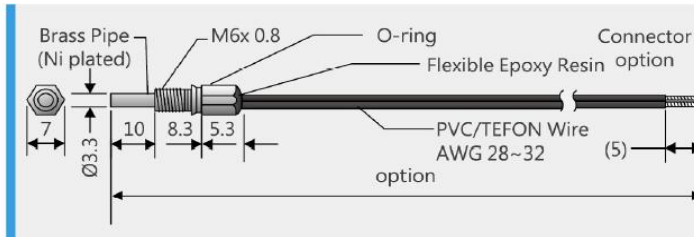

Application :
Boiler , Hot water system
Operating temp. range :
-30~+120°C
Dissipation constant :
Approx. 3mW/°C
Thermal time constant :
Approx. 5 sec
Withstand voltage :
1000V AC for 1 min

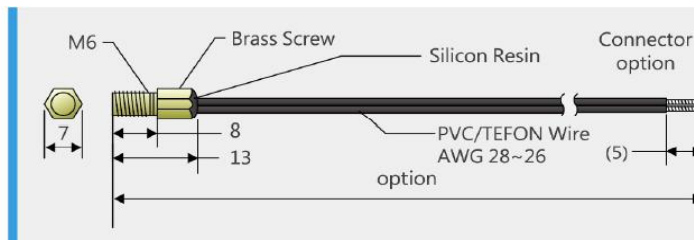

Application :
Coffee Maker
Operating temp. range :
-30~+200°C
Dissipation constant :
Approx. 3mW/°C
Thermal time constant :
Approx. 12 sec
Withstand voltage :
1000V AC for 1 min

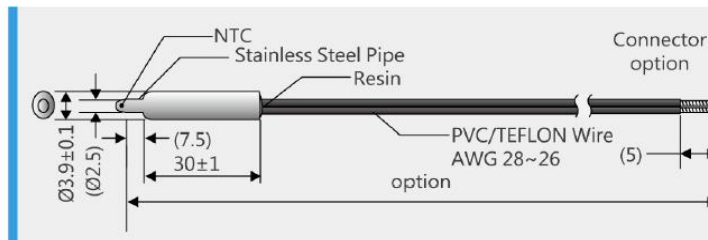

Application :
Boiler , Hot Water Supplier
Operating temp. range :
-30~+120°C
Dissipation constant :
Approx. 2mW/°C
Thermal time constant :
Approx. 3 sec
Withstand voltage :
600V AC for 1 min

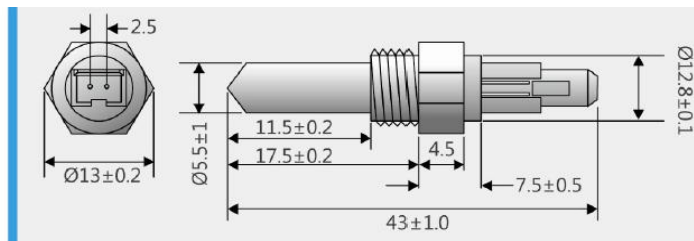

Application :
Boiler , Hot water system
Operating temp. range :
-30~+85°C
Dissipation constant :
Approx. 3mW/°C
Thermal time constant :
Approx. 15 sec
Withstand voltage :
1500V AC for 1 min

Besides The Above Standard Characteristic Product, We Have Some Special Types And Can Provide The Flexible Design According To Your Needs As Well. Please inquire to our sales people for other spec.

APPLICATION -- Fryer

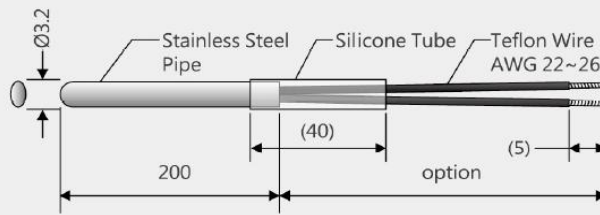

Application :
Cooking Thermometers
Operating temp. range :
-30~+260°C
Dissipation constant :
Approx. 2mW/°C
Thermal time constant :
Approx. 5 sec
Withstand voltage :
1000V AC for 1 min

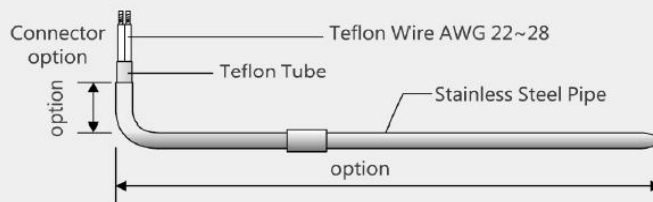

Application :
Fryer
Operating temp. range :
30~+220°C
Dissipation constant :
Approx. 2.5mW/°C
Thermal time constant :
Approx. 10 sec
Withstand voltage :
1000V AC for 1 min

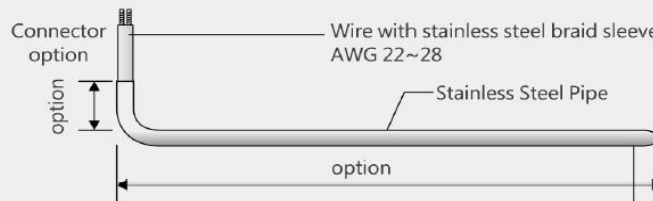

Application :
Fryer
Operating temp. range :
-30~+220°C
Dissipation constant :
Approx. 2.2mW/°C
Thermal time constant :
Approx. 10 sec
Withstand voltage :
1000V AC for 1 min

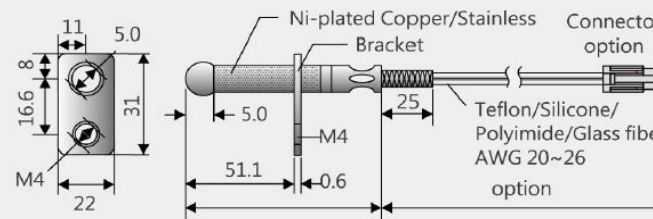

Application :
Fryer
Operating temp. range :
-30~+260°C
Dissipation constant :
Approx. 2.2mW/°C
Thermal time constant :
Approx. 10 sec
Withstand voltage :
1000V AC for 1 min

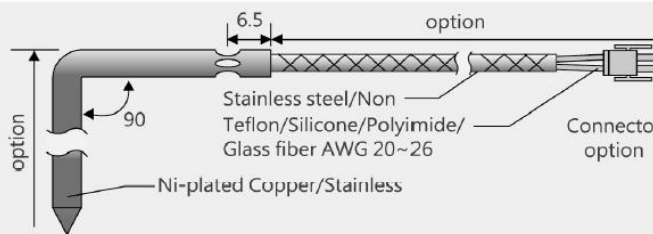

Application :
Fryer
Operating temp. range :
-30~+260°C
Dissipation constant :
Approx. 3mW/°C
Thermal time constant :
Approx. 10 sec
Withstand voltage :
1000V AC for 1 min

Besides The Above Standard Characteristic Product, We Have Some Special Types And Can Provide The Flexible Design According To Your Needs As Well. Please inquire to our sales people for other spec.

APPLICATION -- Microwave oven / Oven

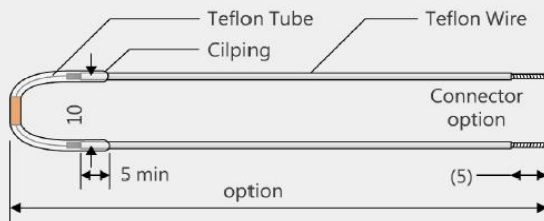

Application :
Home Baker , Rice Cooker
Operating temp. range :
-30~+260°C
Dissipation constant :
Approx. 2.5mW/°C
Thermal time constant :
Approx. 5 sec
Withstand voltage :
1000V AC for 1 min

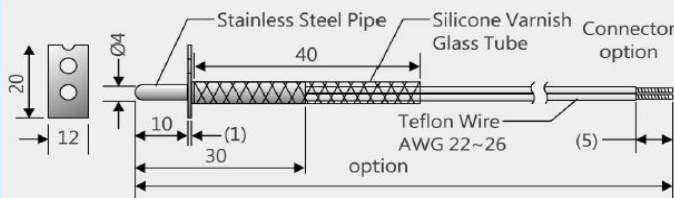

Application :
Home Baker , Microwave oven
Operating temp. range :
-30~+260°C
Dissipation constant :
Approx. 3mW/°C
Thermal time constant :
Approx. 10 sec
Withstand voltage :
1000V AC for 1 min

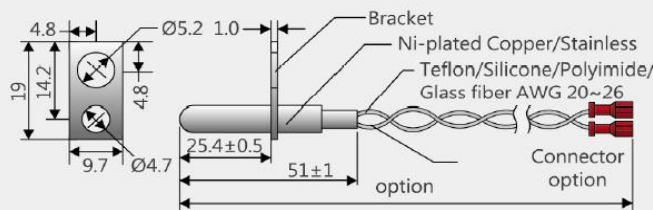

Application :
Home Baker , Microwave oven
Operating temp. range :
-30~+260°C
Dissipation constant :
Approx. 3mW/°C
Thermal time constant :
Approx. 10 sec
Withstand voltage :
1000V AC for 1 min

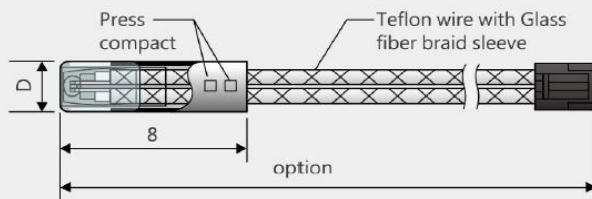

Application :
Home Baker , Microwave oven
Operating temp. range :
-30~+260°C
Dissipation constant :
Approx. 3mW/°C
Thermal time constant :
Approx. 10 sec
Withstand voltage :
1000V AC for 1 min

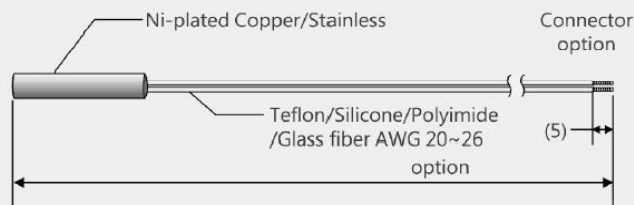

Application :
Home Baker , Microwave oven
Operating temp. range :
-30~+260°C
Dissipation constant :
Approx. 3mW/°C
Thermal time constant :
Approx. 10 sec
Withstand voltage :
1000V AC for 1 min

Besides The Above Standard Characteristic Product, We Have Some Special Types And Can Provide The Flexible Design According To Your Needs As Well. Please inquire to our sales people for other spec.

APPLICATION -- Notebook Battery Pack

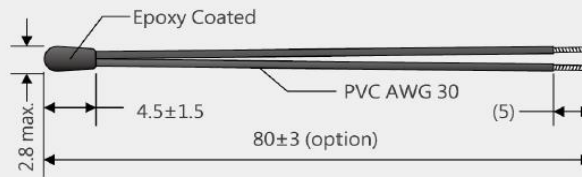

Application :
 Battery Pack
 Operating temp. range :
 -30~+80°C
 Dissipation constant :
 Approx. 1.3mW/°C
 Thermal time constant :
 Approx. 2.5 sec
 Withstand voltage :
 500V AC for 1 min

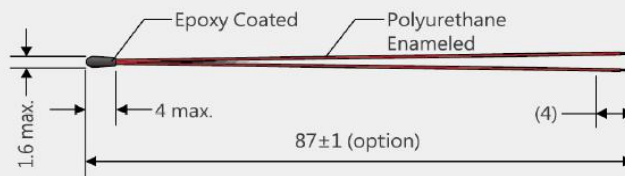

Application :
 Battery Pack , Thermometers
 Operating temp. range :
 -30~+120°C
 Dissipation constant :
 Approx. 0.7mW/°C
 Thermal time constant :
 Approx. 0.8 sec
 Withstand voltage :
 > 50MWΩ. / 500V DC

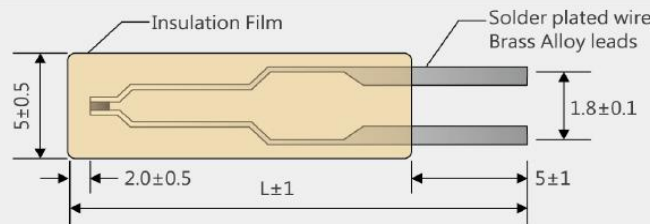

Application :
 Battery Pack
 Operating temp. range :
 -30~+120°C
 Dissipation constant :
 Approx. 0.7mW/°C
 Thermal time constant :
 Approx. 10 sec
 Withstand voltage :
 > 50MWΩ. / 500V DC

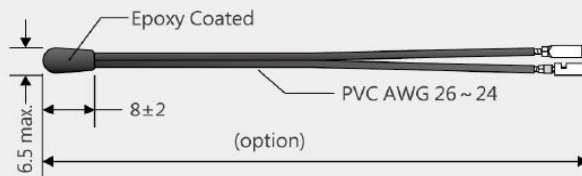

Application :
 Battery Pack
 Operating temp. range :
 -30~+80°C
 Dissipation constant :
 Approx. 1.3mW/°C
 Thermal time constant :
 Approx. 2.5 sec
 Withstand voltage :
 500V AC for 1 min

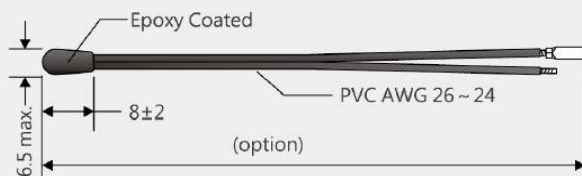

Application :
 Battery Pack
 Operating temp. range :
 -30~+80°C
 Dissipation constant :
 Approx. 1.3mW/°C
 Thermal time constant :
 Approx. 2.5 sec
 Withstand voltage :
 500V AC for 1 min

Besides The Above Standard Characteristic Product, We Have Some Special Types And Can Provide The Flexible Design According To Your Needs As Well. Please inquire to our sales people for other spec.

APPLICATION -- Hot water supplier/Boiler

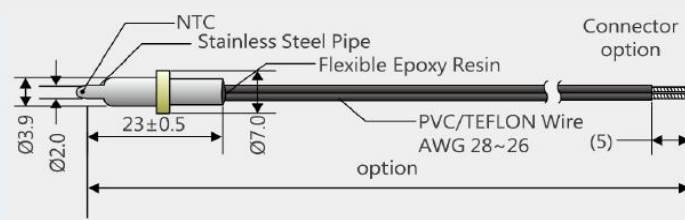

Application :	Boiler , Hot Water Supplier
Operating temp. range :	-30~+120°C
Dissipation constant :	Approx. 2mW/°C
Thermal time constant :	Approx. 1 sec
Withstand voltage :	600V AC for 1 min

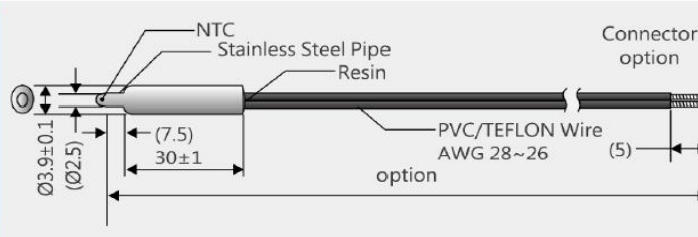

Application :	Boiler , Hot Water Supplier
Operating temp. range :	-30~+120°C
Dissipation constant :	Approx. 2mW/°C
Thermal time constant :	Approx. 3 sec
Withstand voltage :	600V AC for 1 min

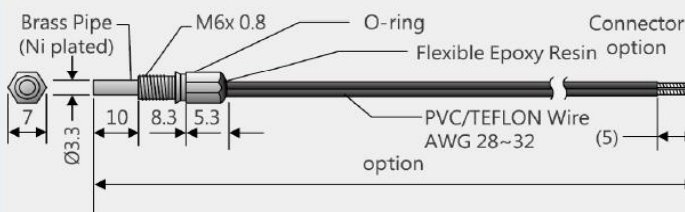

Application :	Hot Water System
Operating temp. range :	-30~+120°C
Dissipation constant :	Approx. 3mW/°C
Thermal time constant :	Approx. 5 sec
Withstand voltage :	1000V AC for 1 min

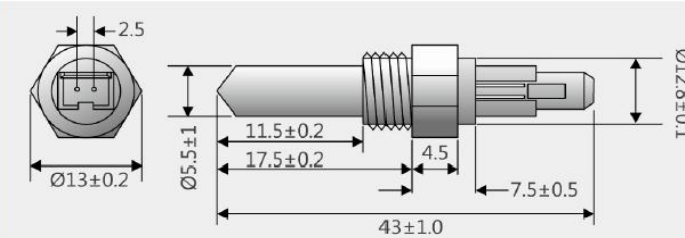

Application :	Boiler , Hot water system
Operating temp. range :	-30~+120°C
Dissipation constant :	Approx. 3mW/°C
Thermal time constant :	Approx. 15 sec
Withstand voltage :	1500V AC for 1 min

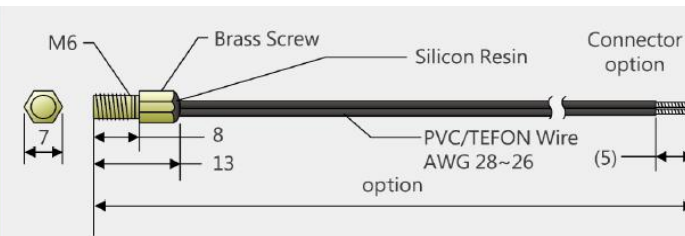

Application :	Boiler , Hot water system
Operating temp. range :	-30~+120°C
Dissipation constant :	Approx. 3mW/°C
Thermal time constant :	Approx. 5 sec
Withstand voltage :	1000V AC for 1 min

Besides The Above Standard Characteristic Product, We Have Some Special Types And Can Provide The Flexible Design According To Your Needs As Well. Please inquire to our sales people for other spec.

APPLICATION -- Power supply/Heater

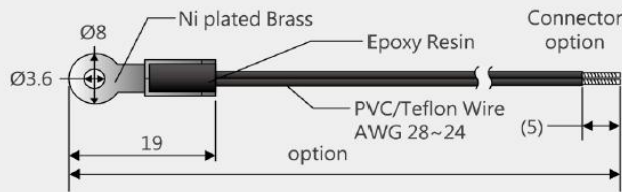

Application :
 Heater , Power
 Operating temp. range :
 -30~+120°C
 Dissipation constant :
 Approx. 2.5mW/°C
 Thermal time constant :
 Approx. 8 sec
 Withstand voltage :
 1500V AC for 1 min

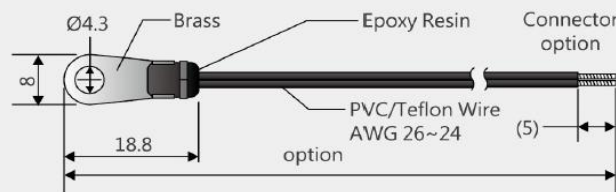

Application :
 Heater , Power
 Operating temp. range :
 -30~+120°C
 Dissipation constant :
 Approx. 2.5mW/°C
 Thermal time constant :
 Approx. 8 sec
 Withstand voltage :
 1500V AC for 1 min

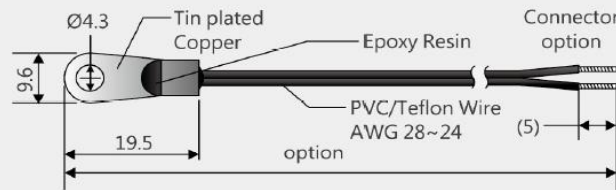

Application :
 Heater , Power
 Operating temp. range :
 -30~+120°C
 Dissipation constant :
 Approx. 2.5mW/°C
 Thermal time constant :
 Approx. 8 sec
 Withstand voltage :
 1500V AC for 1 min

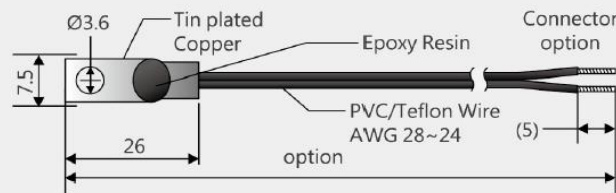

Application :
 Heater , Power
 Operating temp. range :
 -30~+120°C
 Dissipation constant :
 Approx. 2.5mW/°C
 Thermal time constant :
 Approx. 8 sec
 Withstand voltage :
 1500V AC for 1 min

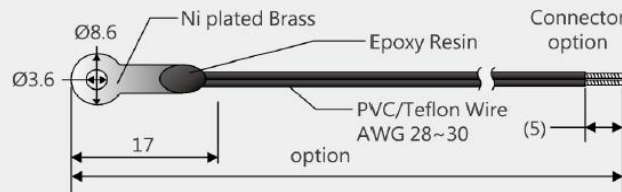

Application :
 Heater , Power
 Operating temp. range :
 -30~+120°C
 Dissipation constant :
 Approx. 2.5mW/°C
 Thermal time constant :
 Approx. 8 sec
 Withstand voltage :
 1500V AC for 1 min

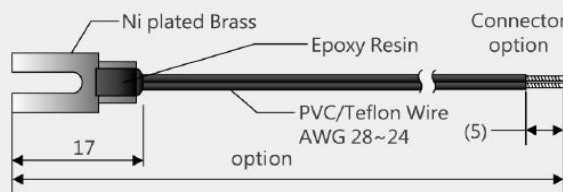

Application :
 Heater , Power
 Operating temp. range :
 -30~+120°C
 Dissipation constant :
 Approx. 2.5mW/°C
 Thermal time constant :
 Approx. 8 sec
 Withstand voltage :
 1500V AC for 1 min

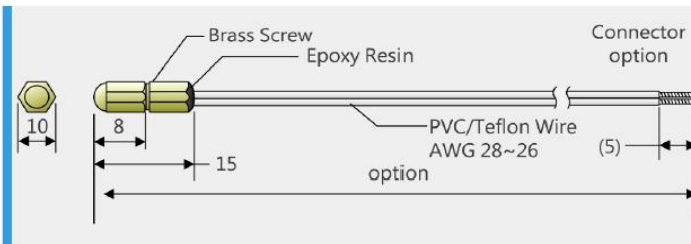

Application :	Heater , Power
Operating temp. range :	-30~+120°C
Dissipation constant :	Approx. 2.5mW/°C
Thermal time constant :	Approx. 12 sec
Withstand voltage :	1500V AC for 1 min

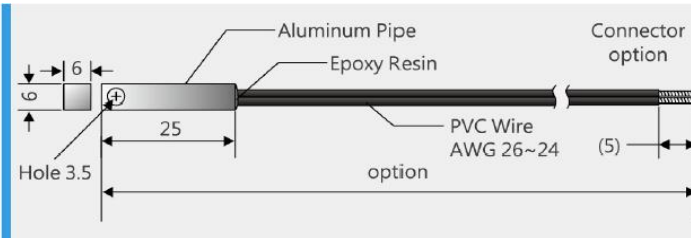

Application :	Heater , Power
Operating temp. range :	-30~+120°C
Dissipation constant :	Approx. 2.5mW/°C
Thermal time constant :	Approx. 18 sec
Withstand voltage :	1800V AC for 1 min

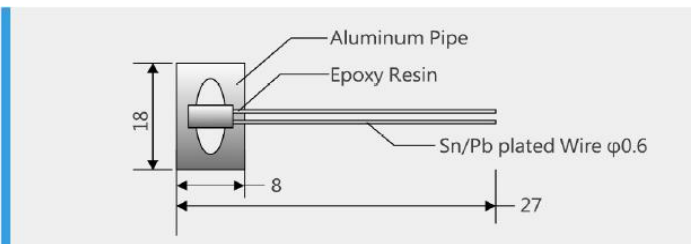

Application :	Surface Temperature Detector
Operating temp. range :	-30~+120°C
Dissipation constant :	Approx. 2mW/°C
Thermal time constant :	Approx. 8 sec
Withstand voltage :	1500V AC for 1 min

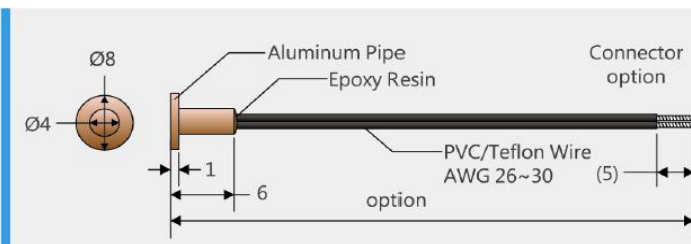

Application :	Heater
Operating temp. range :	-30~+120°C
Dissipation constant :	Approx. 2mW/°C
Thermal time constant :	Approx. 8 sec
Withstand voltage :	1500V AC for 1 min

Besides The Above Standard Characteristic Product, We Have Some Special Types And Can Provide The Flexible Design According To Your Needs As Well. Please inquire to our sales people for other spec.

APPLICATION -- Medicine

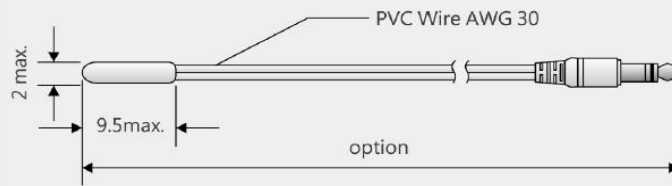

Application :
 Medicine
 Operating temp. range :
 -30~+80°C
 Dissipation constant :
 Approx. 1.5mW/°C
 Thermal time constant :
 Approx. 2 sec
 Withstand voltage :
 1000V AC for 1 min

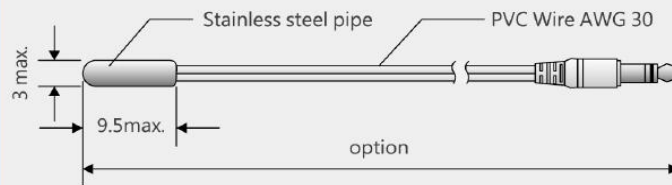

Application :
 Medicine
 Operating temp. range :
 -30~+80°C
 Dissipation constant :
 Approx. 1.5mW/°C
 Thermal time constant :
 Approx. 2 sec
 Withstand voltage :
 1000V AC for 1 min

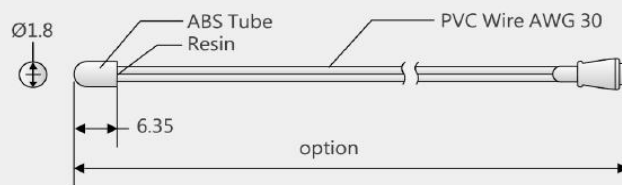

Application :
 Medicine
 Operating temp. range :
 -50~+150°C
 Dissipation constant :
 Approx. 2.5mW/°C
 Thermal time constant :
 Approx. 1.25 sec
 Withstand voltage :
 > 50MWΩ. / 500V DC

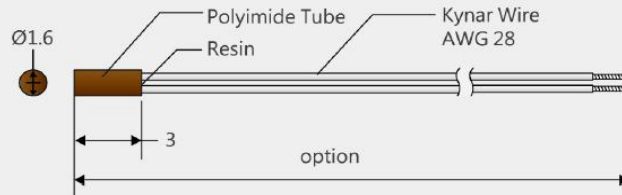

Application :
 Medicine
 Operating temp. range :
 -50~+150°C
 Dissipation constant :
 Approx. 1.5mW/°C
 Thermal time constant :
 Approx. 0.4 sec
 Withstand voltage :
 > 50MWΩ. / 500V DC

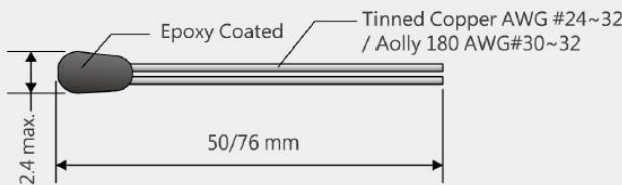

Application :
 Medicine
 Operating temp. range :
 -50~+150°C
 Dissipation constant :
 Approx. 2.0mW/°C
 Thermal time constant :
 Approx. 0.75 sec
 Withstand voltage :
 > 50MWΩ. / 500V DC

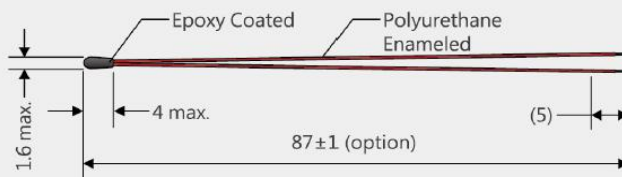

Application :
 Medical Equipment , Thermometers
 Operating temp. range :
 -30~+120°C
 Dissipation constant :
 Approx. 0.7mW/°C
 Thermal time constant :
 Approx. 0.8 sec
 Withstand voltage :
 > 50MWΩ. / 500V DC

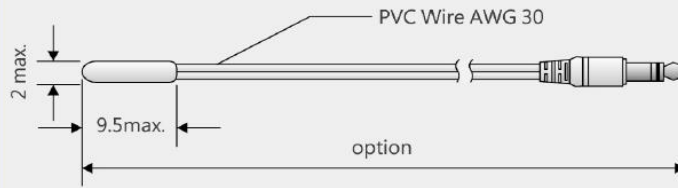

Application :	Medicine
Operating temp. range :	-30~+80°C
Dissipation constant :	Approx. 1.5mW/°C
Thermal time constant :	Approx. 2 sec
Withstand voltage :	1000V AC for 1 min

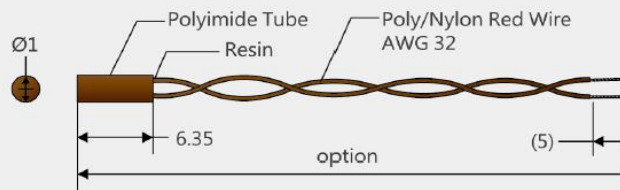

Application :	Medicine
Operating temp. range :	-50~+150°C
Dissipation constant :	Approx. 1.5mW/°C
Thermal time constant :	Approx. 0.4 sec
Withstand voltage :	> 50MWΩ. / 500V DC

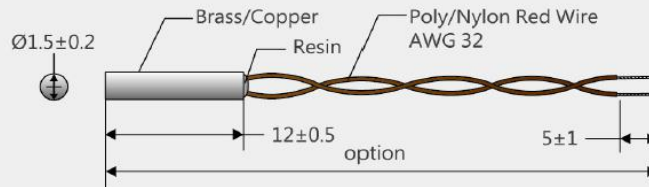

Application :	Medicine
Operating temp. range :	-50~+150°C
Dissipation constant :	Approx. 1.5mW/°C
Thermal time constant :	Approx. 2 sec
Withstand voltage :	> 50MWΩ. / 500V DC

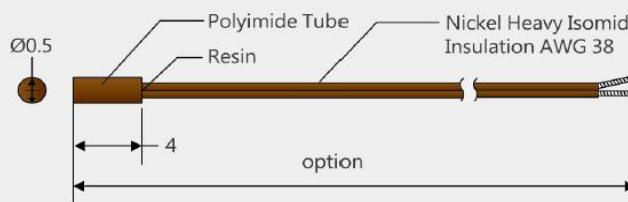

Application :	Medicine
Operating temp. range :	-50~+150°C
Dissipation constant :	Approx. 1.5mW/°C
Thermal time constant :	Approx. 0.4 sec
Withstand voltage :	> 50MWΩ. / 500V DC

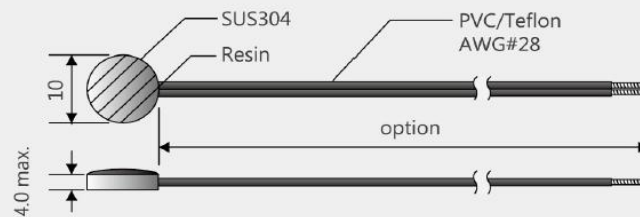

Application :	Medicine
Operating temp. range :	-50~+150°C
Dissipation constant :	Approx. 1.5mW/°C
Thermal time constant :	Approx. 2 sec
Withstand voltage :	> 50MWΩ. / 500V DC

Besides The Above Standard Characteristic Product, We Have Some Special Types And Can Provide The Flexible Design According To Your Needs As Well. Please inquire to our sales people for other spec.

APPLICATION -- Automobile

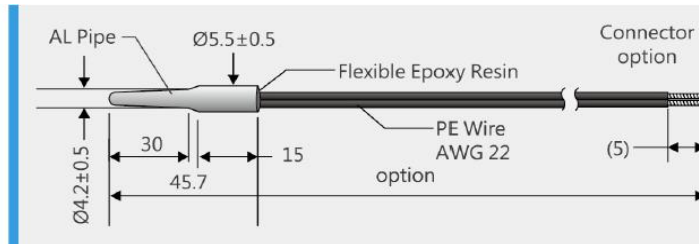

Application :	Intake air
Operating temp. range :	-30~+120°C
Dissipation constant :	Approx. 2mW/°C
Thermal time constant :	Approx. 5 sec
Withstand voltage :	1500V AC for 1 min

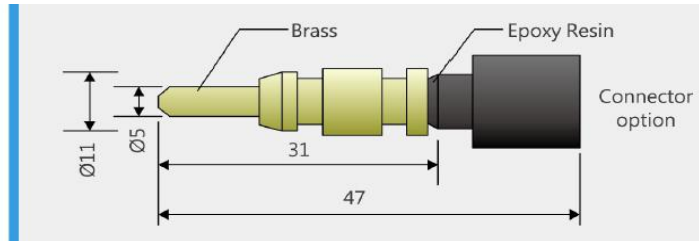

Application :	Water temp.
Operating temp. range :	-30~+120°C
Dissipation constant :	Approx. 2.5mW/°C
Thermal time constant :	Approx. 9 sec
Withstand voltage :	1500V AC for 1 min

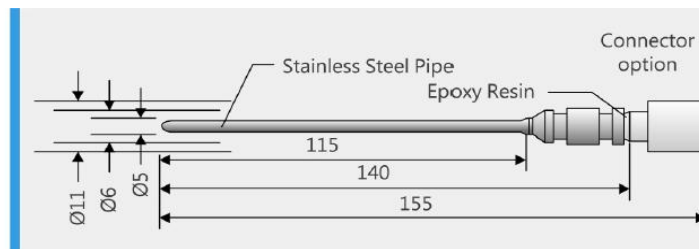

Application :	Water temp.
Operating temp. range :	-30~+120°C
Dissipation constant :	Approx. 3mW/°C
Thermal time constant :	Approx. 15 sec
Withstand voltage :	1500V AC for 1 min

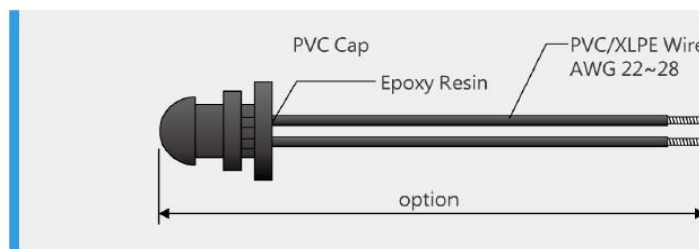

Application :	Water temp.
Operating temp. range :	-30~+150°C
Dissipation constant :	Approx. 3mW/°C
Thermal time constant :	Approx. 15 sec
Withstand voltage :	1500V AC for 1 min

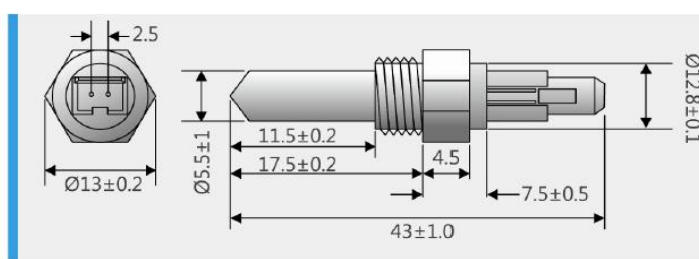

Application :	Water temp.
Operating temp. range :	-30~+150°C
Dissipation constant :	Approx. 3mW/°C
Thermal time constant :	Approx. 15 sec
Withstand voltage :	1500V AC for 1 min

Besides The Above Standard Characteristic Product, We Have Some Special Types And Can Provide The Flexible Design According To Your Needs As Well. Please inquire to our sales people for other spec.

APPLICATION -- Washer

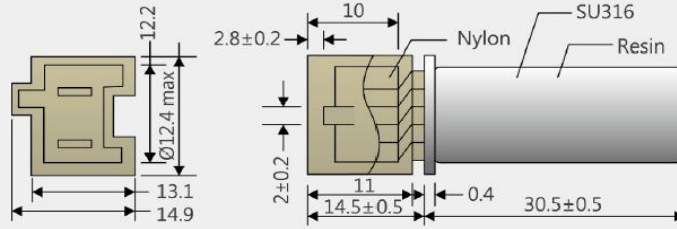

Application :	Washer
Operating temp. range :	-40~+125°C
Dissipation constant :	Approx. 30mW/°C
Thermal time constant :	Approx. 18sec
Withstand voltage :	1000V AC for 1 min

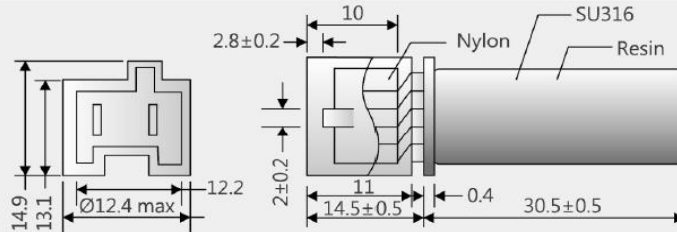

Application :	Washer
Operating temp. range :	-40~+125°C
Dissipation constant :	Approx. 30mW/°C
Thermal time constant :	Approx. 18 sec
Withstand voltage :	1000V AC for 1 min

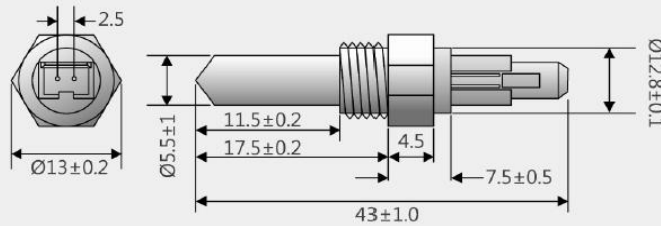

Application :	Washer
Operating temp. range :	-30~+150°C
Dissipation constant :	Approx. 3mW/°C
Thermal time constant :	Approx. 15 sec
Withstand voltage :	1500V AC for 1 min

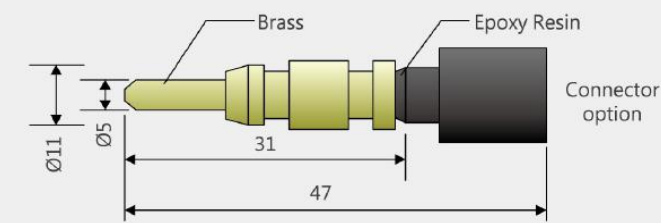

Application :	Washer
Operating temp. range :	-30~+120°C
Dissipation constant :	Approx. 2.5mW/°C
Thermal time constant :	Approx. 9 sec
Withstand voltage :	1500V AC for 1 min

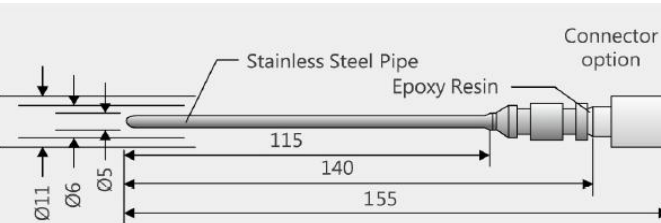

Application :	Washer
Operating temp. range :	-30~+120°C
Dissipation constant :	Approx. 3mW/°C
Thermal time constant :	Approx. 15 sec
Withstand voltage :	1500V AC for 1 min

Besides The Above Standard Characteristic Product, We Have Some Special Types And Can Provide The Flexible Design According To Your Needs As Well. Please inquire to our sales people for other spec.

APPLICATION -- Industry

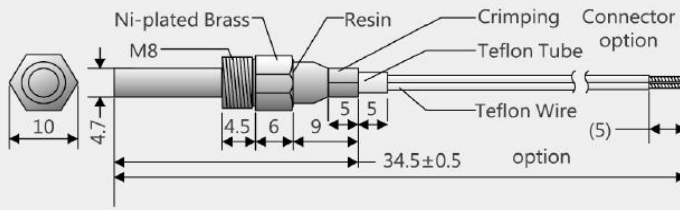

Application :
Industry
Operating temp. range :
-30~+250°C
Dissipation constant :
Approx. 2mW/°C
Thermal time constant :
Approx. 10 sec
Withstand voltage :
1500V AC for 1 min

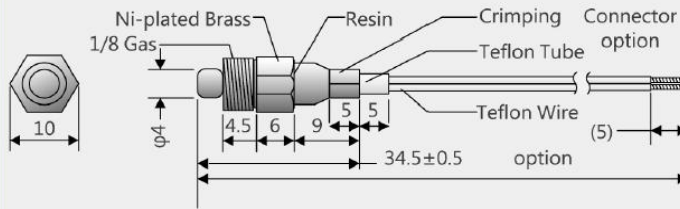

Application :
Industry
Operating temp. range :
-30~+250°C
Dissipation constant :
Approx. 2mW/°C
Thermal time constant :
Approx. 10 sec
Withstand voltage :
1500V AC for 1 min

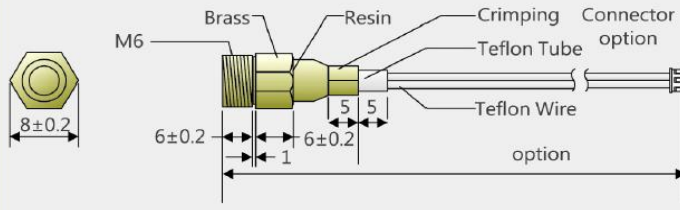

Application :
Industry
Operating temp. range :
-30~+250°C
Dissipation constant :
Approx. 2mW/°C
Thermal time constant :
Approx. 10 sec
Withstand voltage :
1500V AC for 1 min

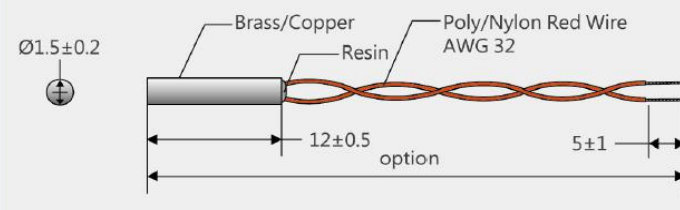

Application :
Industry
Operating temp. range :
-30~+150°C
Dissipation constant :
Approx. 1.5mW/°C
Thermal time constant :
Approx. 2 sec
Withstand voltage :
500V AC for 1 min

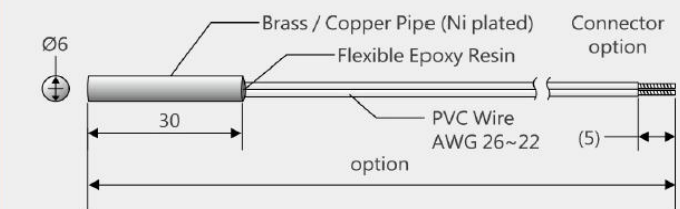

Application :
Industry
Operating temp. range :
-30~+100°C
Dissipation constant :
Approx. 3mW/°C
Thermal time constant :
Approx. 15 sec
Withstand voltage :
1800V AC for 1 min

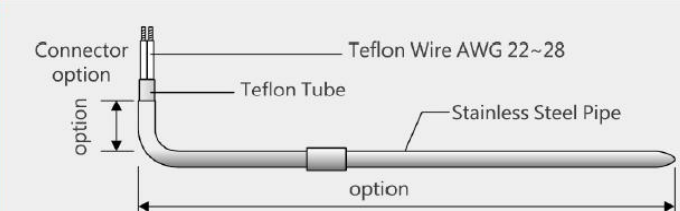

Application :
Industry
Operating temp. range :
-30~+220°C
Dissipation constant :
Approx. 2.5mW/°C
Thermal time constant :
Approx. 10 sec
Withstand voltage :
1000V AC for 1 min

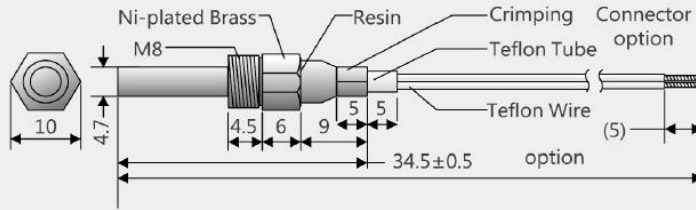

Application :	Industry
Operating temp. range :	-30~+250°C
Dissipation constant :	Approx. 2mW/°C
Thermal time constant :	Approx. 10 sec
Withstand voltage :	1500V AC for 1 min

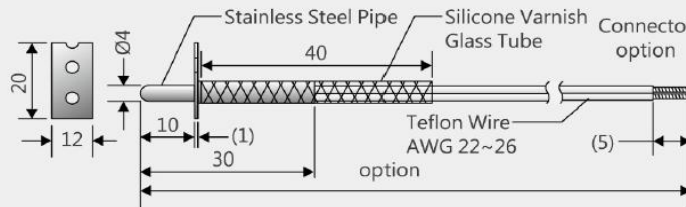

Application :	Industry
Operating temp. range :	-30~+260°C
Dissipation constant :	Approx. 3mW/°C
Thermal time constant :	Approx. 10 sec
Withstand voltage :	1000V AC for 1 min

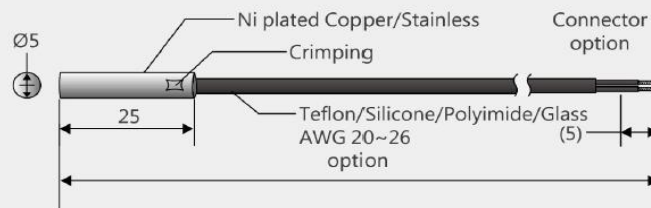

Application :	Industry
Operating temp. range :	-60~+80°C
Dissipation constant :	Approx. 3mW/°C
Thermal time constant :	Approx. 20 sec
Withstand voltage :	1800V AC for 1 min

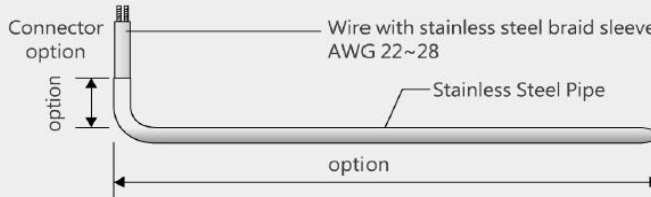

Application :	Industry
Operating temp. range :	-30~+220°C
Dissipation constant :	Approx. 2.2mW/°C
Thermal time constant :	Approx. 10 sec
Withstand voltage :	1000V AC for 1 min

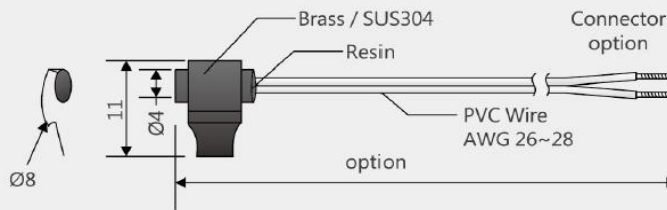

Application :	Industry
Operating temp. range :	-30~+105°C
Dissipation constant :	Approx. 2.2mW/°C
Thermal time constant :	Approx. 10 sec
Withstand voltage :	1500V AC for 1 min

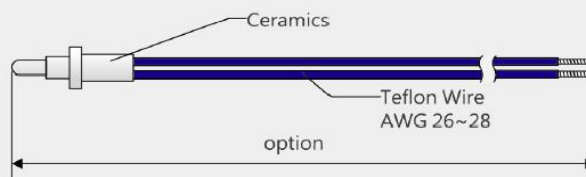

Application :	Industry
Operating temp. range :	-30~+250°C
Dissipation constant :	Approx. 2mW/°C
Thermal time constant :	Approx. 10 sec
Withstand voltage :	1500V AC for 1 min

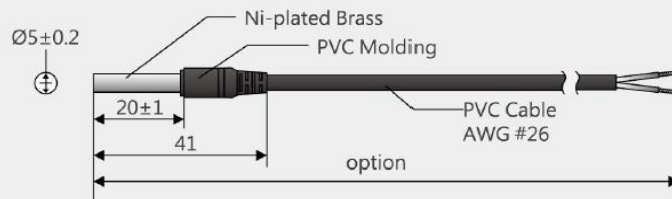

Application :
Industry
Operating temp. range :
-30~+250°C
Dissipation constant :
Approx. 2mW/°C
Thermal time constant :
Approx. 10 sec
Withstand voltage :
1500V AC for 1 min

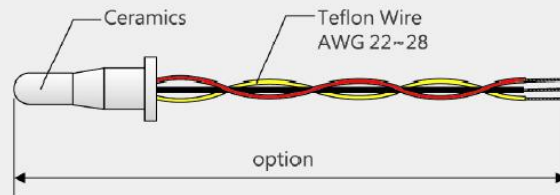

Application :
Industry
Operating temp. range :
-30~+250°C
Dissipation constant :
Approx. 2mW/°C
Thermal time constant :
Approx. 10 sec
Withstand voltage :
1500V AC for 1 min

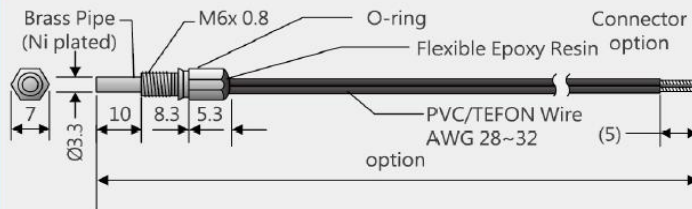

Application :
Industry
Operating temp. range :
-30~+120°C
Dissipation constant :
Approx. 3mW/°C
Thermal time constant :
Approx. 5 sec
Withstand voltage :
1000V AC for 1 min

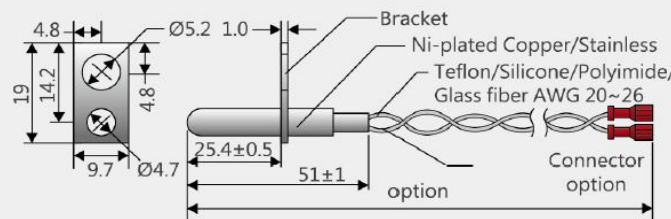

Application :
Industry
Operating temp. range :
-30~+260°C
Dissipation constant :
Approx. 3mW/°C
Thermal time constant :
Approx. 10 sec
Withstand voltage :
1000V AC for 1 min

Besides The Above Standard Characteristic Product, We Have Some Special Types And Can Provide The Flexible Design According To Your Needs As Well. Please inquire to our sales people for other spec.

Automobile water temperature sensors,chip

Product No.: NSC*

Automotive internal temperature sensor is the water temperature sensor, the lower temperature is, the greater the resistance; The smaller the vice resistance, installed in the engine cylinder or cylinder head water jacket, direct contact with cooling water. Which side of the engine cooling water temperature.

汽车水温传感器的内部是汽车水温传感器，温度愈低，电阻愈大；反之电阻愈小，安装在发动机缸体或缸盖的水套上，与冷却水直接接触。从而测得发动机冷却水的温度。

Features:

- ◆ No lead
- ◆ High sensitivity
- ◆ High compatibility and stability
- ◆ Operation temperature range $-40 \sim +125^{\circ}\text{C}$
- ◆ Resistance tolerance: $\pm 3\%, \pm 5\%, \pm 10\%, \pm 15\%, \pm 20\%$

Applications:

- ◆ widely used in automobile, shipping, armored car, combustion engines, oiliness transformer.

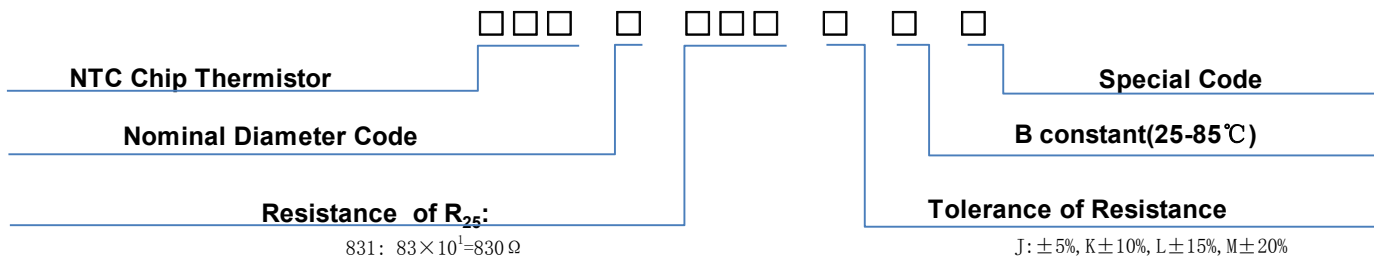

SHAPE & DIMENSIONS

Part No.	D ± 0.3	T ± 0.2	Nominal Resistance at 25°C	Beta Value $\pm 3\%, \pm 5\%$
	(mm)	(mm)	(Ω)	(K, $25/85^{\circ}\text{C}$)
NSCA*	4.9	1.3	880	3600
NSCB*	7.5	1.6	340	3600
NSCC*	5.6	1.5	845	3500
NSCD*	7.2	1.5	570	4000
NSCE*	6.7	1.5	2500	4100
NSCF*	6.5	1.5	2320	4100
NSCG*	5.6	1.5	2420	4150
NSCH*	6.5	1.5	1180	4200
NSCI*	7.3	1.5	420	4200
NSCJ*	5	1.2	820	4200
NSCK*	4.9	1.2	480	4200
NSCL*	5.6	1.3	3200	4200
NSCM*	5	1.4	685	4200
NSCN*	9	1.7	470	4250

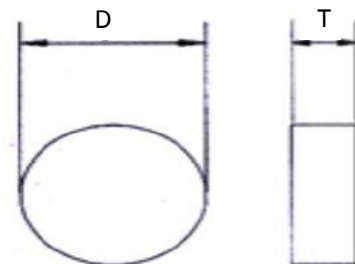
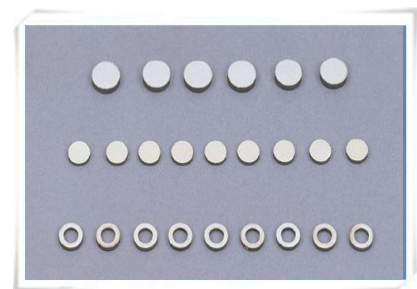

R-T characteristic

Temp. °C	NSCA	NSCB	NSCC	NSCD	NSCE	NSCF	NSCG
-40	25490	9850	22294	24002	126922	107270	114540
-30	12000 ± 10%	5220	12024	11853	60504	52046	55328
-20	6800 ± 14%	2908	6810	6189	30581	26737	28308
-10	4385	1694	4027	3395	16279	14448	15240
0	2700 ± 10%	1027	2474	1946	9076	8168	8585
10	1668	645	1574	1160	5273	4807	5036
20	1080 ± 10%	418	1032	717	3179	2933	3064
25	880	340	845	570	2500	2320	2420
30	720	279	696	457	1982	1849	1926
40	495	191	482	300	1273	1201	1247
50	345	134	341	200 ± 15%	841	801	830
60	247	96	246	139	535 ± 12%	547	566
70	180	70	181	98	394	382	394
80	134	52	136	71	275 ± 16%	273	281
85	116	45	118	60 ± 5%	236	232	238
100	77 ± 6%	30	80	38	140 ± 14%	146	150
107	65	25	67	32 ± 6%	120	119	122
120	48	18	50	22 ± 9%	83	84	85

Temp. °C	NSCH	NSCI	NSCJ	NSCK	NSCL	NSCM	NSCN
-40	59907	21323	41631	24369	162461	34777	25003
-30	28558	10165	19845	11617	77445	16578	11815
-20	14434	5138	10031	5872	39144	8379	5923
-10	7684	2735	5340	3126	20838	4461	3130
0	4284	1525	2977	1743	11617	2487	1733
10	2489	886	1729	1012	6749	1445	1000
20	1500	534	1043	610	4069	871	599
25	1180	420	820	480	3200	685	470
30	935	333	650	380	2537	543	372
40	601	214	418	244	1630	349	237
50	397	141	276	161	1076	230	156
60	269	96	187	109	728	156	105
70	186	66	129	76	505	108	72
80	132	47	91	54	357	76	51
85	111	40	77	45	302	65	43
100	70	25	48	28	189	40	27
107	57	20	39	23	153	33	22
120	39	14	27	16	106	23	15

Note: Resistance range no marking tolerance is ±10%.

NTC Chip Thermistor

The chip thermistor is high precision temperature sensing thermistor. They are designed for close tolerance resistance-temperature curve tracking over two standard temperature ranges. As such, they may be used in any general temperature measurement, control or compensation application where interchangeability and low cost are major considerations. when used as a temperature gauge, the chip thermistor requires no adjustment between the control circuit and the sensor.

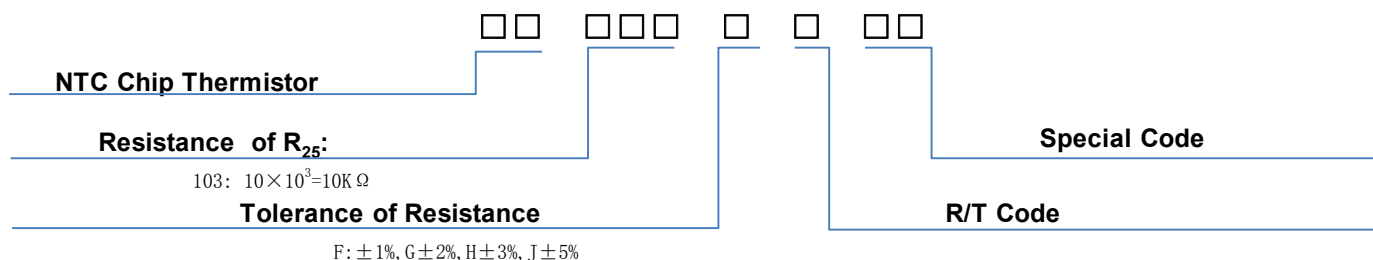

STRUCTURE AND DIMENSIONS

(1) DS Series:

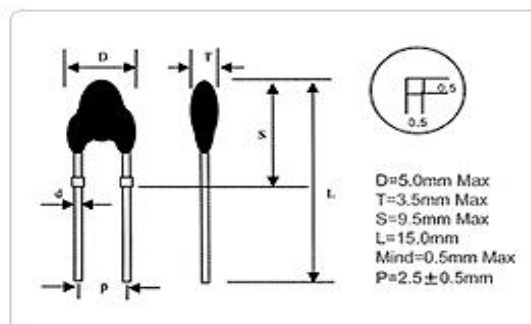

SPECIFICATIONS:

Dissipation Constant	Min. 2.0mW/°C	in still air	Operating Temperature	- 30°C to + 120°C
Thermal Time Constant	Max. 10.0 sec	in still air	Maximum Power Rating	10mW at 25°C

Part No.	Nominal Resistance at 25°C (ohms)	Beta Value (°k)		R/T Code
		0 / 50°C	25 / 85°C	
DS 202 □ A	2,000	3326	3424	A
DS 202 □ F	2,000	3887	3970	F
DS 502 □ R	5,000	3226	3324	R
DS 502 □ B	5,000	3430	3500	B
DS 502 □ F	5,000	3887	3970	F
DS 103 □ U	10,000	3320	3435	U
DS 103 □ C	10,000	3683	3720	C
DS 103 □ F	10,000	3887	3970	F
DS 203 □ O	20,000	3887	3970	O
DS 303 □ O	30,000	3887	3970	O
DS 403 □ O	40,000	3887	3970	O
DS 473 □ O	47,000	3887	3970	O
DS 503 □ Q	50,000	3952	4060	Q
DS 104 □ P	100,000	4019	4200	P
DS 204 □ I	200,000	4180	4391	I

◆ Please inquire to our sales people for other spec.

(3) DF Series:

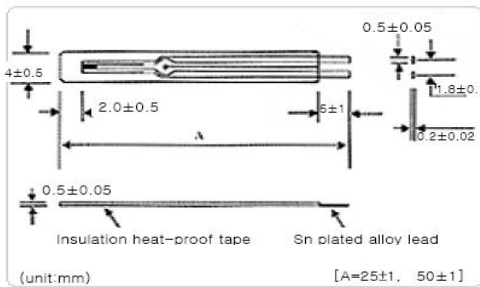

(4) DD Series:

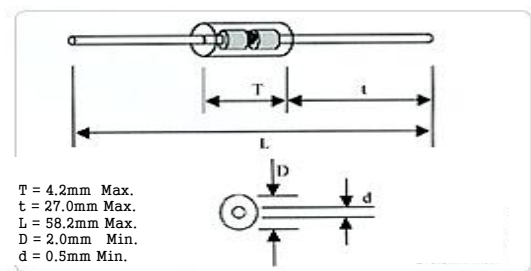

SPECIFICATIONS:

Dissipation Constant	Min. 0.7mW/°C in still air
Thermal Time Constant	Max. 5.0 sec in still air
Operating Temperature	- 30°C to + 100°C
Maximum Power Rating	3.5mW at 25°C

Part No.	Nominal Resistance at 25°C (Ω)	Beta Value (°k)		R/T Code
		0 / 50°C	25 / 85°C	
DF 103 □ U1	10,000	3320	3435	U1
DF 503 □ O	50,000	3887	3970	O
DF 104 □ Q	100,000	3952	4060	Q

◆ Please inquire to our sales people for other spec.

SPECIFICATIONS:

Dissipation Constant	Min. 2.3mW/°C in still air
Thermal Time Constant	Max. 10 sec in still air
Operating Temperature	- 30°C to + 250°C
Maximum Power Rating	10mW at 25°C

Part No.	Nominal Resistance at 25°C (Ω)	Beta Value (°k)		R/T Code
		0 / 50°C	25 / 85°C	
DD 502 □ B1	5,000	3560	3620	B1
DD 502 □ B4	5,000	3430	3500	B4
DD 532 □ B4	5,369	3430	3500	B4
DD 103 □ S	10,000	3320	3435	S
DD 103 □ C	10,000	3683	3720	C
DD 103 □ E	10,000	3887	3970	E
DD 203 □ F	20,000	3887	3970	F
DD 303 □ F	30,000	3887	3970	F
DD 503 □ Q	50,000	3952	4060	Q
DD 104 □ P2	100,000	3919	3990	P2
DD 104 □ P1	100,000	4019	4200	P1
DD 204 □ P	200,000	4019	4200	P
DD 204 □ I	200,000	4180	4319	I
DD 234 □ I1	231,400	4133	4240	I1
DD 504 □ L1	500,000	4298	4500	L1
DD 145 □ L	1,388,000	4243	4815	L

◆ Please inquire to our sales people for other spec.



Resistance - Temperature Standard Curve

Temp.		R / T code																					
°C	°F	A	B	B1	B4	C	E	F	I	II	L	LI	O	O1	P	P1	P2	Q	Q1	R	S	U	U1
-30	-22	11.3270	12.5860	13.9820	12.5860	15.7550	17.6000	17.6000	19.3550	20.7090	14.2420	21.3860	17.6000	16.9220	17.6610	17.6610	18.2260	18.0330	18.0330	10.4890	11.0880	11.0880	11.0880
-25	-13	8.7820	9.6180	10.5530	9.6180	11.7060	12.9830	12.9830	14.3300	15.0480	11.3420	15.6460	12.9830	12.5940	13.1640	13.1640	13.3770	13.3040	13.3040	8.2020	8.6330	8.6330	8.6330
-20	-4	6.8600	7.4150	8.0410	7.4150	8.7910	9.6720	9.6720	10.6770	11.0410	11.3420	15.6460	12.5940	13.1640	13.1640	13.3770	13.3040	13.3040	9.9060	6.4590	6.7680	6.7680	
-15	5	5.3970	5.7640	6.1830	5.7640	6.6700	7.2740	7.2740	8.0060	8.1780	7.0720	8.5520	7.2740	7.1510	7.4640	7.4640	7.4300	7.4410	7.4410	5.1220	5.3420	5.3420	5.3420
-10	14	4.2770	4.5170	4.7950	4.5170	5.1100	5.5200	5.5200	6.0410	6.1130	5.5200	6.3890	5.5200	5.4540	5.6770	5.6770	5.6170	5.6370	5.6370	4.0890	4.2430	4.2430	4.2430
-5	23	3.4110	3.5670	3.7500	3.5670	3.9510	4.2250	4.2250	4.5870	4.6090	4.3490	4.8060	4.2250	4.1910	4.3470	4.3470	4.2850	4.3060	4.3060	3.2850	3.3920	3.3920	3.3920
0	32	2.7390	2.8380	2.9550	2.8380	3.0810	3.2610	3.2610	3.5050	3.5050	3.4020	3.6400	3.2610	3.2450	3.3500	3.3500	3.2980	3.3150	3.3150	2.6560	2.7280	2.7280	2.7280
5	41	2.2130	2.2740	2.3470	2.2740	2.4230	2.5370	2.5370	2.6950	2.6870	2.6600	2.7750	2.5370	2.5300	2.5990	2.5990	2.5590	2.5720	2.5720	2.1600	2.2070	2.2070	2.2070
10	50	1.7990	1.8340	1.8770	1.8340	1.9210	1.9890	1.9890	2.0850	2.0760	2.0800	2.1300	1.9890	1.9860	2.0280	2.0280	2.0010	2.0100	2.0100	1.7670	1.7960	1.7960	1.7960
15	59	1.4710	1.4890	1.5200	1.4890	1.5340	1.5710	1.5710	1.6220	1.6160	1.6270	1.6450	1.5710	1.5700	1.5930	1.5930	1.5770	1.5820	1.5820	1.4540	1.4700	1.4700	1.4700
20	68	1.2100	1.2170	1.2260	1.2170	1.2340	1.2490	1.2490	1.2700	1.2670	1.2750	1.2790	1.2490	1.2490	1.2580	1.2580	1.2510	1.2540	1.2540	1.2030	1.2090	1.2090	1.2090
25	77	1.0000	1.0000	1.0000	1.0000	1.0000	1.0000	1.0000	1.0000	1.0000	1.0000	1.0000	1.0000	1.0000	1.0000	1.0000	1.0000	1.0000	1.0000	1.0000	1.0000	1.0000	1.0000
30	86	0.8310	0.8270	0.8210	0.8270	0.8150	0.8060	0.8060	0.7920	0.7950	0.7860	0.7870	0.8060	0.8050	0.7990	0.7990	0.8050	0.8030	0.8030	0.8360	0.8310	0.8310	0.8310
35	95	0.6940	0.6870	0.6780	0.6870	0.6690	0.6530	0.6530	0.6300	0.6360	0.6190	0.6230	0.6530	0.6520	0.6420	0.6420	0.6510	0.6480	0.6480	0.7020	0.6940	0.6940	0.6940
40	104	0.5830	0.5740	0.5630	0.5740	0.5520	0.5330	0.5330	0.5050	0.5120	0.4890	0.4950	0.5330	0.5310	0.5190	0.5190	0.5310	0.5270	0.5270	0.5920	0.5830	0.5830	0.5830
45	113	0.4910	0.4820	0.4700	0.4820	0.4580	0.4370	0.4370	0.4060	0.4140	0.3870	0.3960	0.4370	0.4350	0.4210	0.4210	0.4350	0.4300	0.4300	0.5020	0.4910	0.4910	0.4910
50	122	0.4160	0.4070	0.3940	0.4070	0.3830	0.3610	0.3610	0.3280	0.3370	0.3080	0.3190	0.3610	0.3580	0.3440	0.3440	0.3580	0.3530	0.3530	0.4270	0.4160	0.4160	0.4160
55	131	0.3540	0.3450	0.3320	0.3450	0.3210	0.2990	0.2990	0.2670	0.2760	0.2450	0.2580	0.2990	0.2970	0.2820	0.2820	0.2970	0.2920	0.2920	0.3650	0.3540	0.3540	0.3540
60	140	0.3030	0.2940	0.2810	0.2940	0.2710	0.2490	0.2490	0.2180	0.2270	0.1960	0.2100	0.2490	0.2470	0.2320	0.2320	0.2470	0.2420	0.2420	0.3130	0.3020	0.3020	0.3020
65	149	0.2600	0.2510	0.2390	0.2510	0.2290	0.2090	0.2090	0.1790	0.1880	0.1570	0.1710	0.2090	0.2060	0.1920	0.1920	0.2070	0.2020	0.2020	0.2700	0.2590	0.2590	0.2590
70	158	0.2240	0.2160	0.2050	0.2160	0.1950	0.1760	0.1760	0.1470	0.1560	0.1260	0.1400	0.1760	0.1730	0.1600	0.1600	0.1740	0.1690	0.1690	0.2340	0.2230	0.2230	0.2230
75	167	0.1930	0.1860	0.1760	0.1860	0.1670	0.1480	0.1480	0.1220	0.1310	0.1020	0.1160	0.1480	0.1460	0.1340	0.1340	0.1470	0.1420	0.1420	0.2030	0.1920	0.1920	0.1920
80	176	0.1680	0.1610	0.1510	0.1610	0.1430	0.1260	0.1260	0.1020	0.1100	0.0823	0.0959	0.1260	0.1230	0.1120	0.1120	0.1250	0.1200	0.1200	0.1770	0.1670	0.1670	0.1670
85	185	0.1460	0.1400	0.1310	0.1400	0.1240	0.1070	0.1070	0.0848	0.0923	0.0669	0.0798	0.1070	0.1050	0.0944	0.0944	0.1060	0.1020	0.1020	0.1540	0.1450	0.1450	0.1450
90	194	0.1280	0.1220	0.1140	0.1220	0.1070	0.0920	0.0920	0.0711	0.0781	0.0545	0.0666	0.0920	0.0895	0.0798	0.0798	0.0909	0.0871	0.0871	0.1350	0.1270	0.1270	0.1270
95	203	0.1120	0.1070	0.0990	0.1070	0.0930	0.0790	0.0790	0.0599	0.0664	0.0445	0.0559	0.0790	0.0766	0.0678	0.0678	0.0781	0.0745	0.0745	0.1190	0.1110	0.1110	0.1110
100	212	0.0984	0.0937	0.0865	0.0937	0.0811	0.0682	0.0682	0.0506	0.0567	0.0365	0.0471	0.0682	0.0659	0.0577	0.0577	0.0674	0.0640	0.0640	0.1052	0.0974	0.0974	0.0974
105	221	0.0868	0.0825	0.0759	0.0825	0.0710	0.0590	0.0590	0.0429	0.0485	0.0300	0.0398	0.0590	0.0569	0.0494	0.0494	0.0583	0.05520	0.05520	0.0931	0.0858	0.0858	0.0858
110	230	0.0768	0.0729	0.0668	0.0729	0.0623	0.0513	0.0513	0.0365	0.0417	0.0248	0.0337	0.0513	0.0492	0.0424	0.0424	0.0506	0.0477	0.0477	0.0827	0.0758	0.0758	0.0758
115	239	0.0681	0.0646	0.0590	0.0646	0.0549	0.0447	0.0447	0.0312	0.0360	0.0205	0.0287	0.0447	0.0428	0.0365	0.0365	0.0441	0.0414	0.0414	0.0736	0.0672	0.0672	0.0672
120	248	0.0606	0.0574	0.0520	0.0574	0.0485	0.0391	0.0391	0.0267	0.0312	0.0170	0.0246	0.0391	0.0373	0.0315	0.0315	0.0386	0.0361	0.0361	0.0657	0.0597	0.0597	0.0597
125	257	0.0541	0.0512	0.0464	0.0512	0.0430	0.0343	0.0343	0.0230	0.0271	0.0142	0.0211	0.0343	0.0326	0.0273	0.0273	0.0338	0.0315	0.0315	0.0588	0.0532	0.0532	0.0532
130	266	0.0484	0.0457	0.0413	0.0457	0.0382	0.0302	0.0302	0.0198	0.0236	0.0119	0.0181	0.0302	0.0286	0.0237	0.0237	0.0298	0.0276	0.0276	0.0527	0.0475	0.0475	0.0475
135	275	0.0434	0.0409	0.0369	0.0409	0.0341	0.0266	0.0266	0.0172	0.0206	0.0100	0.0156	0.0266	0.0251	0.0207	0.0207	0.0263	0.0243	0.0243	0.0474	0.0425	0.0425	0.0425
140	284	0.0390	0.0368	0.0330	0.0368	0.0304	0.0236	0.0236	0.0149	0.0181	0.0084	0.0135	0.0236	0.0222	0.0181	0.0181	0.0223	0.0214	0.0214	0.0427	0.0382	0.0382	0.0382
145	293	0.0351	0.0331	0.0296	0.0331	0.0273	0.0209	0.0209	0.0130	0.0159	0.0071	0.0117	0.0209	0.0196	0.0159	0.0159	0.0206	0.0189	0.0189	0.0386	0.0344	0.0344	0.0344
150	302	0.0317	0.0299	0.0267	0.0299	0.0245	0.0186	0.0186	0.0113	0.0140	0.0060	0.0102	0.0186	0.0174	0.0140	0.0140	0.0184	0.0168	0.0168	0.0350	0.0310	0.0310	0.0310
155	311	0.0287	0.0270	0.0240	0.0270	0.0221	0.0166	0.0166	0.0099	0.0124	0.0051	0.0089	0.0166	0.0154	0.0123	0.0123	0.0164	0.0149	0.0149	0.0317	0.0280	0.0280	0.0280
160	320	0.0260	0.0245	0.0217	0.0245	0.0199	0.0148	0.0148	0.0087	0.0110	0.0043	0.0078	0.0148	0.0138	0.0109	0.0109	0.0147	0.0133	0.0133	0.0288	0.0254	0.0254	0.0254
165	329	0.0236	0.0222	0.0197	0.0222	0.0180	0.0133	0.0133	0.0077	0.0098	0.0037	0.0069	0.0133	0.0123	0.0096	0.0096	0.0131	0.0119	0.0119	0.0263	0.0230	0.0230	0.0230
170	338	0.0215	0.0202	0.0179	0.0202	0.0163	0.0120	0.0120	0.0068	0.0087	0.0031	0.0061	0.0120	0.0110	0.0086	0.0086	0.0118	0.0106	0.0106	0.0240	0.0209	0.0209	0.0209
175	347	0.0196	0.0185	0.0163	0.0185	0.0149	0.0108	0.0108	0.0060	0.0078	0.0027	0.0053	0.0108	0.0099	0.0076	0.0076	0.0106	0.0095	0.0095	0.0219	0.0191	0.0191	0.0191
180	356	0.0180	0.0169	0.0148	0.0169	0.0135	0.0097	0.0097	0.0053	0.0070	0.0023	0.0047	0.0097	0.0089	0.0068	0.0068	0.0096	0.0086	0.0086	0.0201	0.0174	0.0174	0.0174
185	365	0.0164	0.0154	0.0135	0.0154	0.0123	0.0088	0.0088	0.0047	0.0063	0.0020	0.0042	0.0088	0.0080	0.0061	0.0061	0.0087	0.0077	0.0077	0.0185	0.0159	0.0159	0.0159
190	374	0.0151	0.0142	0.0124	0.0142	0.0113	0.0080	0.0080	0.0042	0.0056	0.0017	0.0037	0.0080	0.0072	0.0055	0.0055	0.0079	0.0070	0.0070	0.0170	0.0146	0.0146	0.0146
195	383	0.0139	0.0130	0.0113	0.0130	0.0103	0.0072	0.0072	0.0038	0.0051	0.0015	0.0033	0.0072	0.0066	0.0049	0.0049	0.0072	0.0063	0.0063	0.0156	0.0134	0.0134	0.0134

NTC Small Size Thermistor Series

Product No.: DC*

Features:

- ◆ Small precision type
- ◆ Excellent thermal cycle endurance
- ◆ Rapid time response quality
- ◆ Thermal time constant \cong 12 sec
- ◆ Thermal dissipation constant \cong 3 mW/°C
- ◆ Operation temperature range -30 ~ +125 °C
- ◆ Resistance tolerance: \pm 1%, \pm 2%, \pm 3%, \pm 5%, \pm 10%

Applications:

- ◆ Temperature detection for mother boards
- ◆ Temperature-humidity clock
- ◆ Notebook computer's battery chargers

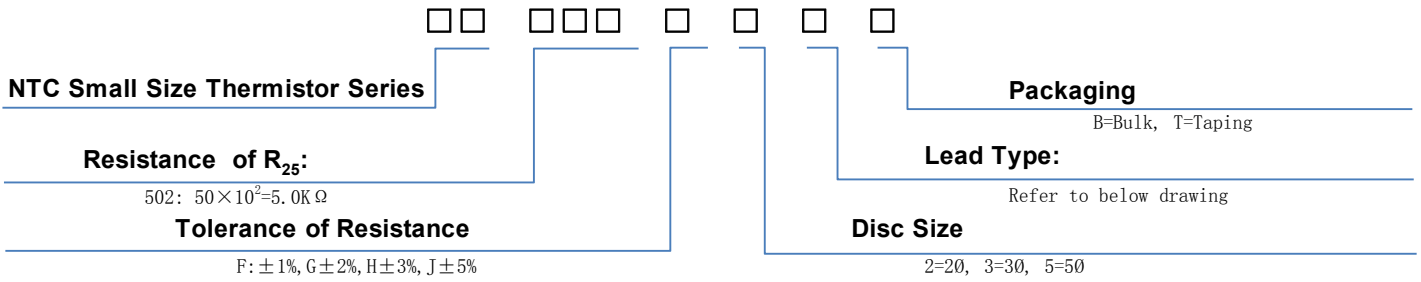

SHAPE & DIMENSIONS

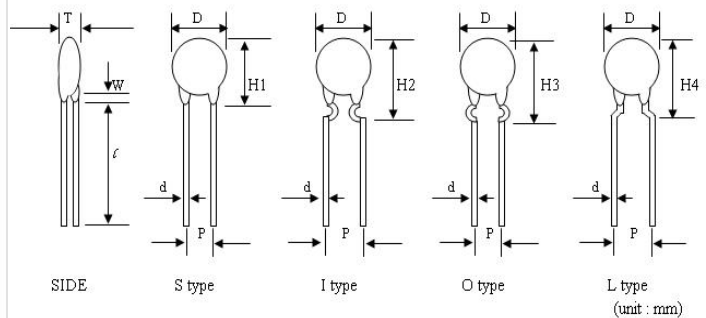
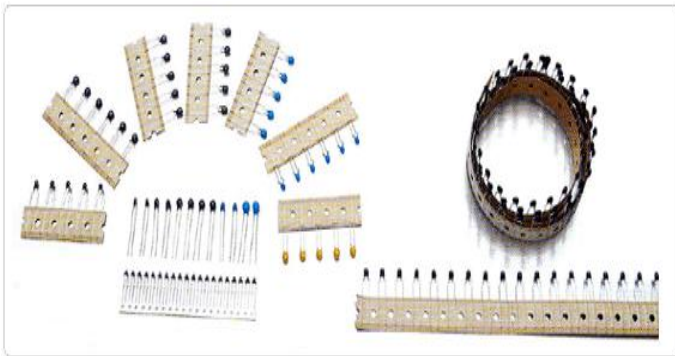

Series	D	T	l	d	P (pitch)			W	H1	H2	H3	H4
					S / O	I	L					
2	max. 3.0	max. 3.0	min 25.0	$\varnothing 0.50 \pm 0.02$	2.5	5	2.5	3.0	5.0	7.0	7.0	6.5
3	max. 3.8	max. 3.2			-0.2	-0.2	5.0	3.0	7.0	8.5	8.5	7.0
5	max. 6.0	max. 3.5			+0.5	+0.5	5.0	3.0	8.0	9.0	9.0	8.0

* P : Lead wire space ** W : Lead coating length

*** Lead cut length is variable upon request L= min.3.0 ~ max.8.0mm

Resistance - Temperature Graph

2mm Series

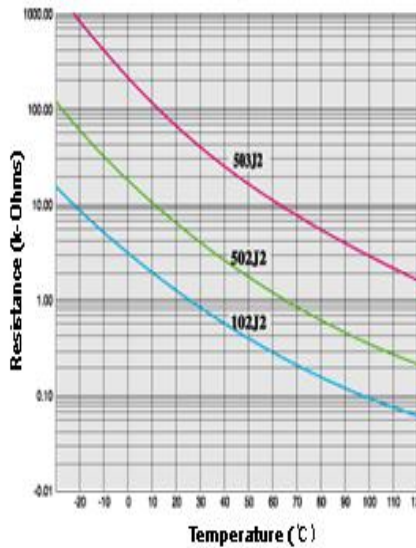

3mm Series

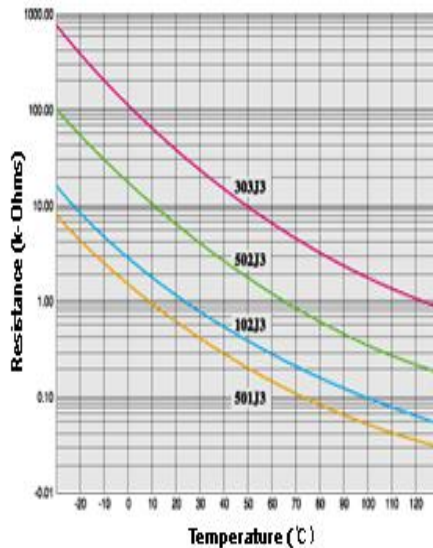

5mm Series

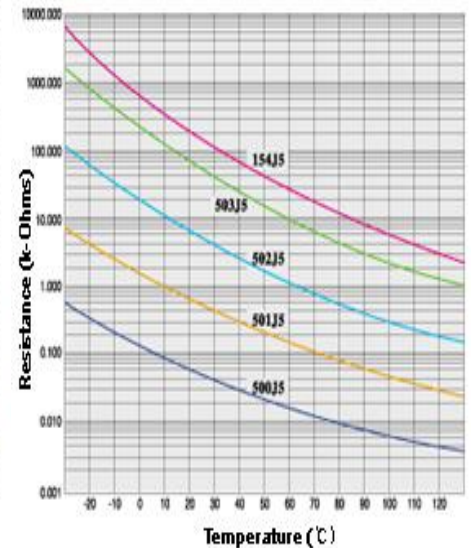

2mm Series :

Nominal Diameter (mm)	Part No.	Nominal Resistance at 25°C (ohms)	R.Tolerance ±(%)	Beta Value (K, 25/85 °C)	Rated Power at 25°C (mW)	Dissipation Constant (mW/°C)	Time Constant (Sec.)	Max. Operating Temp.(°C)
Ø2	DC102 □ 2◇△	1,000	1,2,3,5,10	3500	100	2.0	8	120
	DC202 □ 2◇△	2,000	1,2,3,5,10	3550	100	2.0	8	120
	DC302 □ 2◇△	3,000	1,2,3,5,10	3620	100	2.0	8	120
	DC402 □ 2◇△	4,000	1,2,3,5,10	3750	100	2.0	8	120
	DC472 □ 2◇△	4,700	1,2,3,5,10	3850	100	2.0	8	120
	DC502 □ 2◇△	5,000	1,2,3,5,10	3850	100	2.0	8	120
		5,000	1,2,3,5,10	3910	100	2.0	8	120
	DC103 □ 2◇△	10,000	1,2,3,5,10	3435	100	2.0	8	120
		10,000	1,2,3,5,10	3500	100	2.0	8	120
		10,000	1,2,3,5,10	3950	100	2.0	8	120
	DC123 □ 2◇△	12,000	1,2,3,5,10	3970	100	2.0	8	120
	DC153 □ 2◇△	15,000	1,2,3,5,10	4000	100	2.0	8	120
	DC203 □ 2◇△	20,000	1,2,3,5,10	4050	100	2.0	8	120
	DC253 □ 2◇△	25,000	1,2,3,5,10	4050	100	2.0	8	120
	DC303 □ 2◇△	30,000	1,2,3,5,10	4100	100	2.0	8	120
	DC333 □ 2◇△	33,000	1,2,3,5,10	4100	100	2.0	8	120
	DC473 □ 2◇△	47,000	1,2,3,5,10	4150	100	2.0	8	120
	DC503 □ 2◇△	50,000	1,2,3,5,10	4200	100	2.0	8	120
	DC683 □ 2◇△	68,000	1,2,3,5,10	4200	100	2.0	8	120
	DC104 □ 2◇△	100,000	1,2,3,5,10	4350	100	2.0	8	120
DC154 □ 2◇△	150,000	1,2,3,5,10	4400	100	2.0	8	120	
DC204 □ 2◇△	200,000	1,2,3,5,10	4500	100	2.0	8	120	
DC224 □ 2◇△	220,000	1,2,3,5,10	4500	100	2.0	8	120	
DC404 □ 2◇△	400,000	1,2,3,5,10	4750	100	2.0	8	120	

□ = R. Tolerance : F = ± 1%; G = ± 2%; H = ± 3%; J = ± 5%; K = ± 10%;

◇=Lead Type; △=Taping Form

3mm Series :

Nominal Diameter (mm)	Part No.	Nominal Resistance at 25°C (ohms)	R.Tolerance ±(%)	Beta Value (K, 25/85°C)	Rated Power at 25°C (mW)	Dissipation Constant (mW/°C)	Time Constant (Sec.)	Max. Operating Temp.(°C)
Ø3	DC101 □ 3◇△	100	1,2,3,5,10	3180	200	2.8	14	120
	DC121 □ 3◇△	120	1,2,3,5,10	3180	200	2.8	14	120
	DC151 □ 3◇△	150	1,2,3,5,10	3180	200	2.8	14	120
	DC201 □ 3◇△	200	1,2,3,5,10	3200	200	2.8	14	120
	DC501 □ 3◇△	500	1,2,3,5,10	3430	200	2.8	14	120
	DC102 □ 3◇△	1,000	1,2,3,5,10	3600	200	2.8	14	120
	DC152 □ 3◇△	1,500	1,2,3,5,10	3560	200	2.8	14	120
		1,500	1,2,3,5,10	4150	200	2.8	14	120
	DC202 □ 3◇△	2,000	1,2,3,5,10	3750	200	2.8	14	120
		2,000	1,2,3,5,10	4200	200	2.8	14	120
	DC222 □ 3◇△	2,200	1,2,3,5,10	3750	200	2.8	14	120
	DC252 □ 3◇△	2,500	1,2,3,5,10	3750	200	2.8	14	120
	DC272 □ 3◇△	2,700	1,2,3,5,10	3800	200	2.8	15	120
	DC302 □ 3◇△	3,000	1,2,3,5,10	3850	200	2.8	15	120
	DC332 □ 3◇△	3,300	1,2,3,5,10	3850	200	2.8	15	120
	DC402 □ 3◇△	4,000	1,2,3,5,10	3850	200	2.8	15	120
	DC472 □ 3◇△	4,700	1,2,3,5,10	3900	200	2.8	15	120
	DC502 □ 3◇△	5,000	1,2,3,5,10	3450	200	2.9	15	120
		5,000	1,2,3,5,10	3900	200	2.9	15	120
	DC682 □ 3◇△	6,800	1,2,3,5,10	3900	200	2.9	15	120
	DC103 □ 3◇△	10,000	1,2,3,5,10	3450	200	3.0	15	120
		10,000	1,2,3,5,10	3970	200	3.0	15	120
		10,000	1,2,3,5,10	4040	200	3.0	15	120
	DC123 □ 3◇△	12,000	1,2,3,5,10	3970	200	3.0	15	120
	DC153 □ 3◇△	15,000	1,2,3,5,10	4050	200	3.0	15	120
		15,000	1,2,3,5,10	4150	200	3.0	15	120
	DC203 □ 3◇△	20,000	1,2,3,5,10	4100	200	3.0	16	120
	DC223 □ 3◇△	22,000	1,2,3,5,10	4100	200	3.0	16	120
	DC253 □ 3◇△	25,000	1,2,3,5,10	4150	200	3.0	16	120
	DC303 □ 3◇△	30,000	1,2,3,5,10	4150	200	3.0	16	120
	DC333 □ 3◇△	33,000	1,2,3,5,10	4150	200	3.0	16	120
	DC403 □ 3◇△	40,000	1,2,3,5,10	4200	200	3.0	16	120
	DC473 □ 3◇△	47,000	1,2,3,5,10	4250	200	3.0	16	120
	DC503 □ 3◇△	50,000	1,2,3,5,10	4280	200	3.0	16	120
	DC683 □ 3◇△	68,000	1,2,3,5,10	4350	200	3.0	16	120
	DC104 □ 3◇△	100,000	1,2,3,5,10	4350	200	3.0	16	120
		100,000	1,2,3,5,10	4500	200	3.0	16	120
	DC154 □ 3◇△	150,000	1,2,3,5,10	4600	200	3.0	16	120
	DC204 □ 3◇△	200,000	1,2,3,5,10	4700	200	3.0	16	120
	DC224 □ 3◇△	220,000	1,2,3,5,10	4720	200	3.0	16	120
	DC244 □ 3◇△	240,000	1,2,3,5,10	4450	200	3.0	16	120
	DC304 □ 3◇△	300,000	1,2,3,5,10	4800	200	3.0	16	120
	DC334 □ 3◇△	330,000	1,2,3,5,10	4800	200	3.0	16	120
	DC404 □ 3◇△	400,000	1,2,3,5,10	4900	200	3.0	16	120
	DC474 □ 3◇△	470,000	1,2,3,5,10	4750	200	3.0	16	120
470,000		1,2,3,5,10	50000	200	3.0	16	120	
DC504 □ 3◇△	500,000	1,2,3,5,10	5050	200	3.0	16	120	
DC105 □ 3◇△	1,000,000	1,2,3,5,10	5300	200	3.0	16	120	

□ = R. Tolerance : F = ± 1%; G = ± 2%; H = ± 3%; J = ± 5%; K = ± 10%;

◇=Lead Type; △=Taping Form

5mm Series :

Nominal Diameter (mm)	Part No.	Nominal Resistance at 25°C (ohms)	R.Tolerance \pm (%)	Beta Value (K, 25/85°C)	Rated Power at 25°C (mW)	Dissipation Constant (mW/°C)	Time Constant (Sec.)	Max. Operating Temp.(°C)
Ø5	DC100 □ 5◇△	10	1,2,3,5,10	3100	450	7.2	18	120
	DC150 □ 5◇△	15	1,2,3,5,10	3100	450	7.2	18	120
	DC200 □ 5◇△	20	1,2,3,5,10	3100	450	7.2	18	120
	DC330 □ 5◇△	33	1,2,3,5,10	3150	450	7.2	18	120
	DC450 □ 5◇△	45	1,2,3,5,10	3180	450	7.2	18	120
	DC500 □ 5◇△	50	1,2,3,5,10	3180	450	7.2	18	120
	DC700 □ 5◇△	70	1,2,3,5,10	3200	450	7.2	18	120
	DC850 □ 5◇△	85	1,2,3,5,10	3230	450	7.2	18	120
	DC900 □ 5◇△	90	1,2,3,5,10	3230	450	7.2	18	120
	DC101 □ 5◇△	100	1,2,3,5,10	3260	450	7.2	18	120
	DC121 □ 5◇△	120	1,2,3,5,10	3300	450	7.2	18	120
	DC201 □ 5◇△	200	1,2,3,5,10	3400	450	7.2	18	120
	DC221 □ 5◇△	220	1,2,3,5,10	3400	450	7.2	18	120
	DC251 □ 5◇△	250	1,2,3,5,10	3450	450	7.2	18	120
	DC301 □ 5◇△	300	1,2,3,5,10	3500	450	7.2	18	120
	DC351 □ 5◇△	350	1,2,3,5,10	3500	450	7.2	18	120
	DC401 □ 5◇△	400	1,2,3,5,10	3550	450	7.2	18	120
	DC501 □ 5◇△	500	1,2,3,5,10	3600	450	7.2	18	120
	DC601 □ 5◇△	600	1,2,3,5,10	3600	450	7.2	18	120
	DC681 □ 5◇△	680	1,2,3,5,10	3650	450	7.2	18	120
	DC801 □ 5◇△	800	1,2,3,5,10	3750	450	7.2	18	120
	DC901 □ 5◇△	900	1,2,3,5,10	3750	450	7.2	18	120
	DC102 □ 5◇△	1,000	1,2,3,5,10	3750	450	7.3	18	120
		1,000	1,2,3,5,10	3850	450	7.3	18	120
	DC142 □ 5◇△	1,400	1,2,3,5,10	3800	450	7.3	18	120
	DC152 □ 5◇△	1,500	1,2,3,5,10	3800	450	7.3	18	120
	DC202 □ 5◇△	2,000	1,2,3,5,10	3850	450	7.3	18	120
	DC222 □ 5◇△	2,200	1,2,3,5,10	3850	450	7.3	18	120
	DC252 □ 5◇△	2,500	1,2,3,5,10	3900	450	7.3	18	120
	DC272 □ 5◇△	2,700	1,2,3,5,10	3900	450	7.3	19	120
	DC302 □ 5◇△	3,000	1,2,3,5,10	3900	450	7.3	19	120
	DC332 □ 5◇△	3,300	1,2,3,5,10	3900	450	7.3	19	120
	DC352 □ 5◇△	3,500	1,2,3,5,10	3900	450	7.3	19	120
	DC402 □ 5◇△	4,000	1,2,3,5,10	3950	450	7.3	19	120
	DC452 □ 5◇△	4,500	1,2,3,5,10	3950	450	7.3	19	120
	DC472 □ 5◇△	4,700	1,2,3,5,10	4000	450	7.3	19	120
	DC502 □ 5◇△	5,000	1,2,3,5,10	4050	450	7.3	19	120
	DC682 □ 5◇△	6,800	1,2,3,5,10	4050	450	7.3	19	120
	DC103 □ 5◇△	10,000	1,2,3,5,10	4050	450	7.5	19	120
		10,000	1,2,3,5,10	4150	450	7.5	19	120
10,000		1,2,3,5,10	4250	450	7.5	19	120	
DC123 □ 5◇△	12,000	1,2,3,5,10	4150	450	7.5	19	120	
DC153 □ 5◇△	15,000	1,2,3,5,10	4200	450	7.5	19	120	
DC203 □ 5◇△	2,000	1,2,3,5,10	4260	450	7.5	20	120	
DC253 □ 5◇△	25,000	1,2,3,5,10	4300	450	7.5	20	120	

□ = R. Tolerance : F = \pm 1%; G = \pm 2%; H = \pm 3%; J = \pm 5%; K = \pm 10%;

◇=Lead Type; △=Taping Form

5mm Series :

Nominal Diameter (mm)	Part No.	Nominal Resistance at 25°C (ohms)	R.Tolerance ±(%)	Beta Value (K, 25/85°C)	Rated Power at 25°C (mW)	Dissipation Constant (mW/°C)	Time Constant (Sec.)	Max. Operating Temp.(°C)
Ø5	DC303 □ 5◇△	30,000	1,2,3,5,10	4400	450	7.5	20	120
	DC333 □ 5◇△	33,000	1,2,3,5,10	4400	450	7.5	20	120
	DC403 □ 5◇△	40,000	1,2,3,5,10	4450	450	7.5	20	120
	DC473 □ 5◇△	47,000	1,2,3,5,10	4550	450	7.5	20	120
	DC503 □ 5◇△	50,000	1,2,3,5,10	4450	450	7.5	20	120
		50,000	1,2,3,5,10	4600	450	7.5	20	120
	DC104 □ 5◇△	100,000	1,2,3,5,10	4750	450	7.5	20	120
	DC154 □ 5◇△	150,000	1,2,3,5,10	4900	450	7.5	20	120
	DC204 □ 5◇△	200,000	1,2,3,5,10	4638	450	7.5	20	120
		200,000	1,2,3,5,10	5000	450	7.5	20	120
	DC224 □ 5◇△	220,000	1,2,3,5,10	5000	450	7.5	20	120
	DC334 □ 5◇△	330,000	1,2,3,5,10	5050	450	7.5	20	120
	DC404 □ 5◇△	400,000	1,2,3,5,10	5200	450	7.5	20	120
	DC474 □ 5◇△	470,000	1,2,3,5,10	5100	450	7.5	20	120
470,000		1,2,3,5,10	5350	450	7.5	20	120	
DC504 □ 5◇△	500,000	1,2,3,5,10	5350	450	7.5	20	120	

□ = R. Tolerance : F = ± 1%; G = ± 2%; H = ± 3%; J = ± 5%; K = ± 10%;

◇=Lead Type; △=Taping Form

NTC Power Thermistor

Inrush currents are high current levels that occur in some electrical circuits at the instant when power is switched to the circuits. Thermistor components with Negative Temperature Coefficients (NTC) are useful in reducing the magnitude of inrush currents. NTC thermistors that are used for this purpose are referred to as inrush current limiters. A suitable inrush current limiter in a circuit operates by providing a resistive load, at start-up, in series with the circuit to be protected. This reduces the current that is drawn as a start-up surge. As current flows in the circuit, power is dissipated in the thermistor, its bulk temperature increases and its resistance drops to a negligible value. This process typically happens within a few milliseconds of circuit power-up, but the resistance of the NTC remains high enough for sufficient time to limit the inrush current.

This is indicated in Fig 1 and illustrates the ICL (Inrush Current Limiting) function. The low resistance value is maintained in the steady state operating condition of the circuit by the power dissipation in the thermistor which keeps its body temperature at a suitable level.

A typical application of ICL devices is indicated in the schematic diagram (Fig 2) of a switch mode power supply where the ICL provides a resistance in series with the filter capacitors which have low impedance in the uncharged condition at circuit power-up.

Typical ICL effect on Inrush Current in Switch Mode power supply

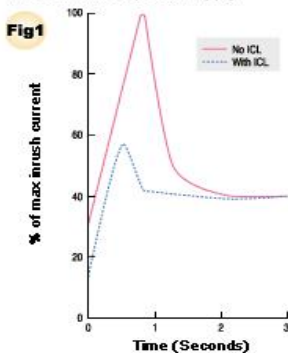

Typical application of ICL in SMPSU

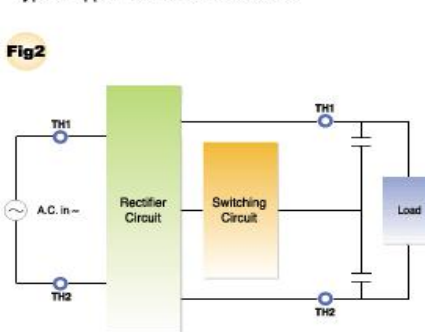

Product No.: DSP*

Features:

- ◆ High inrush current restriction effect
- ◆ High thermal and electrical stability
- ◆ Wide selection of electrical characteristics
- ◆ Operating temperature range from -40°C to $+180^{\circ}\text{C}$
- ◆ Maximum temperature rating of $+250^{\circ}\text{C}$
- ◆ Available in tape format for high volume requirements.
- ◆ Resistance tolerances : $\pm 10\%$, $\pm 15\%$ and $\pm 20\%$ on R25 values
- ◆ Straight or in/out kinked leads of tinned or nickel plated copper wire
- ◆ Useable in series connections up to 250 V rms.

Applications:

- ◆ Power Supplies (Switching Mode).
- ◆ Transformers
- ◆ Filament Lamps
- ◆ Projector Lamps
- ◆ Personal Computers
- ◆ Video Monitors
- ◆ Soft Start Motors

Part Number Code

	□ □ □	□ □ □	□ □ □	□	□	□
NTC Power Thermistor						Packaging
						B=Bulk, T=Taping
Resistance of R_{25}:						Lead Type
0R7=0.7 Ω , 005 =5 Ω , 010=10 Ω , 120=120 Ω						S: Straight, Y: Forming
Disc Size						Tolerance of Resistance
D5=5 ϕ , D8=8 ϕ , D10=10 ϕ , (50 ~ 300)						K: $\pm 10\%$; L: $\pm 15\%$, M $\pm 20\%$, N $\pm 25\%$

Shape And Dimensions

(1). S Type (Straight lead)

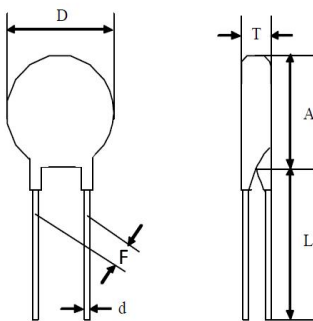

Disk Size	Dmax.	F	d	Amax.	Lmin.	Tmax.
Ø05	6.5	4 \pm 1	0.5 \pm 0.02	6.5	31	4
Ø08	9.5	5 \pm 1	0.6 \pm 0.02	9.5	31	5
Ø10	11.5	7.5 \pm 1	0.8 \pm 0.02	11.5	31	5
Ø13	14.5	7.5 \pm 1	0.8 \pm 0.02	14.5	29	6
Ø15	16.5	7.5 \pm 1	1.0 \pm 0.02	15.6	29	6
Ø20	22.5	7.5 \pm 1	1.0 \pm 0.02	21.5	25	6
Ø25	29.0	7.5 \pm 1	1.0 \pm 0.02	29.0	22	7
Ø30	35.0	10 \pm 1	1.0 \pm 0.02	36.0	23	8

(2). Y Type (Forming lead)

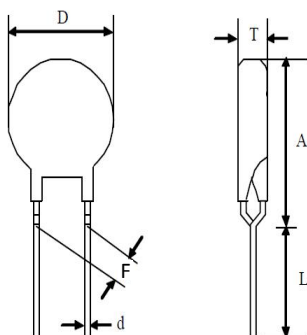

Disk Size	Dmax.	F	d	Amax.	Lmin.	Tmax.
Ø05	6.5	4 \pm 1	0.5 \pm 0.02	11.0	29	4
Ø08	9.5	5 \pm 1	0.6 \pm 0.02	13.0	29	5
Ø10	11.5	7.5 \pm 1	0.8 \pm 0.02	15.0	29	5
Ø13	14.5	7.5 \pm 1	0.8 \pm 0.02	17.5	27	6
Ø15	16.5	7.5 \pm 1	1.0 \pm 0.02	19.0	26	6
Ø20	22.5	7.5 \pm 1	1.0 \pm 0.02	24.5	25	6
Ø25	29.0	7.5 \pm 1	1.0 \pm 0.02	35.0	22	7
Ø30	35.0	10 \pm 1	1.0 \pm 0.02	42.0	22	8

Part No.	Zero Power Resistance at 25°C	Max. Current at 25°C	Residual Resistance at 25°C I _{max}	Max. Power Rating at 25°C	Dissipation Factor	Thermal Time Constant	Operating Temperature Range	B Value R _{25/85} ±10%
	R ₂₅ (Ω)	I _{max} (A)	R _{I_{max}} (Ω)	P _{max} (W)	δ (mW/C)	τ (Sec.)	T _L ~T _H (°C)	(K)
DSP004D8□□□	4	2.0	0.441	2.3	Approx. 16	Approx. 38	-40 ~ +170	2900
DSP4R7D8□□□	4.7	2.0	0.445					
DSP005D8□□□	5	3.0	0.261					
DSP006D8□□□	6	3.0	0.283					
DSP007D8□□□	7	3.0	0.287					
DSP008D8□□□	8	2.0	0.520					
DSP010D8□□□	10	2.0	0.542					
DSP015D8□□□	15	2.0	0.548					
DSP020D8□□□	20	1.0	1.544					
DSP030D8□□□	30	0.5	4.094					3100
DSP001D10□□□	1	5.0	0.091	2.4	Approx. 17	Approx. 43	-40 ~ +170	2900
DSP1R3D10□□□	1.3	5.0	0.095					
DSP1R5D10□□□	1.5	5.0	0.101					
DSP2R5D10□□□	2.5	5.0	0.120					
DSP003D10□□□	3	5.0	0.127					
DSP004D10□□□	4	4.0	0.161					
DSP005D10□□□	5	4.0	0.180					
DSP6R8D10□□□	6.8	3.0	0.270					
DSP008D10□□□	8	3.0	0.278					
DSP010D10□□□	10	3.0	0.297					
DSP012D10□□□	12	3.0	0.301					
DSP013D10□□□	13	3.0	0.356					
DSP015D10□□□	15	2.5	0.442					
DSP016D10□□□	16	2.5	0.471					
DSP020D10□□□	20	2.0	0.646					
DSP022D10□□□	22	2.0	0.659					
DSP025D10□□□	25	2.0	0.674					
DSP030D10□□□	30	2.0	0.700					
DSP047D10□□□	47	2.0	0.720					
DSP050D10□□□	50	2.0	0.813					
DSP080D10□□□	80	1.0	2.236					
DSP100D10□□□	100	1.0	2.318					
DSP120D10□□□	120	1.0	2.406					
DSP001D13□□□	1	3.0	0.174	3.1	Approx. 18	Approx. 66	-40 ~ +200	2900
DSP1R3D13□□□	1.3	7.0	0.070					
DSP2R5D13□□□	2.5	6.0	0.094					
DSP004D13□□□	4	5.0	0.132					
DSP4R7D13□□□	4.7	4.0	0.168					
DSP005D13□□□	5	5.0	0.166					
DSP007D13□□□	7	4.0	0.184					
DSP008D13□□□	8	4.0	0.206					
DSP010D13□□□	10	4.0	0.217					
DSP012D13□□□	12	4.0	0.230					
DSP015D13□□□	15	3.0	0.343					
DSP016D13□□□	16	3.0	0.348					
DSP018D13□□□	18	3.0	0.365					
DSP020D13□□□	20	3.0	0.410					

Part No.	Zero Power Resistance at 25°C	Max. Current at 25°C	Residual Resistance at 25°C I _{max}	Max. Power Rating at 25°C	Dissipation Factor	Thermal Time Constant	Operating Temperature Range	B Value R _{25/85} ±10%
	R ₂₅ (Ω)	I _{max} (A)	R _I max (Ω)	P _{max} (W)	δ (mW/°C)	τ (Sec.)	T _L ~T _U (°C)	(K)
DSP0R7D15□□□	0.7	8.0	0.051	3.6	Approx. 21	Approx. 75	-40 ~ +200	2900
DSP001D15□□□	1	8.0	0.054					
DSP1R3D15□□□	1.3	8.0	0.064					
DSP1R5D15□□□	1.5	8.0	0.068					
DSP002D15□□□	2	8.0	0.078					
DSP2R5D15□□□	2.5	8.0	0.086					
DSP003D15□□□	3	7.0	0.091					
DSP004D15□□□	4	6.0	0.117					
DSP005D15□□□	5	6.0	0.121					
DSP006D15□□□	6	5.0	0.159					
DSP007D15□□□	7	5.0	0.161					
DSP008D15□□□	8	5.0	0.165					
DSP010D15□□□	10	5.0	0.178					
DSP012D15□□□	12	5.0	0.185					
DSP015D15□□□	15	4.0	0.261					
DSP016D15□□□	16	4.0	0.265					
DSP018D15□□□	18	4.0	0.273					
DSP020D15□□□	20	4.0	0.283					
DSP022D15□□□	22	4.0	0.308					
DSP025D15□□□	25	3.0	0.425					
DSP030D15□□□	30	3.0	0.461					
DSP033D15□□□	33	3.0	0.484					
DSP040D15□□□	40	3.0	0.511					
DSP047D15□□□	47	3.0	0.517					
DSP080D15□□□	80	2.5	0.693					
DSP120D15□□□	120	2.0	1.010					
DSP0R7D20□□□	0.7	15.0	0.035	4.9	Approx. 28	Approx. 113	-40 ~ +200	3100
DSP001D20□□□	1	13.0	0.034					
DSP1R5D20□□□	1.5	10.5	0.041					
DSP002D20□□□	2	10.0	0.062					
DSP2R5D20□□□	2.5	9.0	0.083					
DSP003D20□□□	3	8.5	0.078					
DSP004D20□□□	4	8.0	0.080					
DSP4R7D20□□□	4.7	7.5	0.114					
DSP005D20□□□	5	7.5	0.118					
DSP006D20□□□	6	7.0	0.120					
DSP6R8D20□□□	6.8	6.5	0.130					
DSP007D20□□□	7	6.5	0.132					
DSP008D20□□□	8	6.0	0.161					
DSP010D20□□□	10	5.5	0.196					
DSP012D20□□□	12	5.0	0.197					
DSP013D20□□□	13	5.0	0.213					
DSP015D20□□□	15	4.5	0.258					
DSP016D20□□□	16	4.5	0.276					
DSP018D20□□□	18	4.0	0.280					
DSP020D20□□□	20	4.0	0.306					
								3150

Part No.	Zero Power Resistance at 25°C	Max. Current at 25°C	Residual Resistance at 25°C I _{max}	Max.Power Rating at 25°C	Dissipation Factor	Thermal Time Constant	Operating Temperature Range	B Value R ₂₅ /85 ±10%
	R ₂₅ (Ω)	I _{max} (A)	R _{I_{max}} (Ω)	P _{max} (W)	δ (mW/°C)	τ (Sec.)	T _L ~T _U (°C)	(K)
DSP001D25□□□	1	20.0	0.020	7.0	Approx. 30	Approx. 130	-40 ~ +200	2900
DSP1R5D25□□□	1.5	18.5	0.023					
DSP002D25□□□	2	18.0	0.025					
DSP2R5D25□□□	2.5	15.0	0.032					
DSP003D25□□□	3	14.5	0.042					
DSP004D25□□□	4	14.0	0.044					3000
DSP4R7D25□□□	4.7	13.0	0.052					
DSP005D25□□□	5	12.0	0.061					
DSP6R8D25□□□	6.8	10.5	0.082					
DSP007D25□□□	7	10.0	0.092					
DSP008D25□□□	8	9.0	0.115					3100
DSP010D25□□□	10	8.0	0.141					
DSP012D25□□□	12	7.5	0.164					
DSP015D25□□□	15	6.5	0.210					
DSP018D25□□□	18	5.5	0.231					
DSP020D25□□□	20	5.0	0.270	8.0	Approx. 40	Approx. 190	-40 ~ +200	2900
DSP001D30□□□	1	30.0	0.016					
DSP1R5D30□□□	1.5	25.0	0.020					
DSP002D30□□□	2	23.0	0.022					
DSP2R5D30□□□	2.5	18.0	0.030					
DSP003D30□□□	3	17.0	0.035					3000
DSP004D30□□□	4	16.0	0.048					
DSP4R7D30□□□	4.7	15.0	0.055					
DSP005D30□□□	5	14.0	0.057					
DSP6R8D30□□□	6.8	12.0	0.077					
DSP007D30□□□	7	11.5	0.084					3100
DSP008D30□□□	8	10.5	0.100					
DSP010D30□□□	10	10.0	0.115					
DSP012D30□□□	12	9.0	0.142					
DSP015D30□□□	15	8.0	0.175					
DSP018D30□□□	18	7.0	0.210	0.233				
DSP020D30□□□	20	6.0						

∴ Please inquire to our sales people for other spec.

Taping Information

(1) Lead Spacing (F) : 5mm

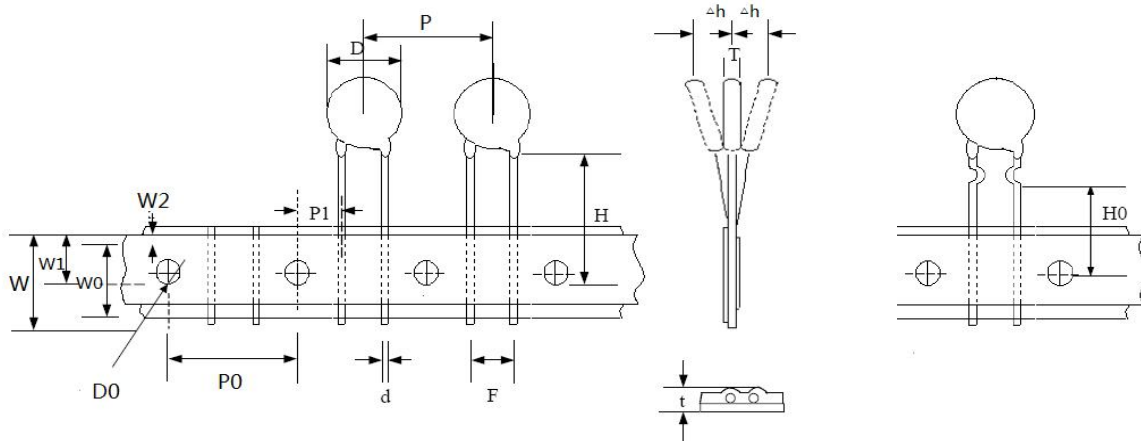

(2) Lead Spacing (F) : 7.5mm, 10mm

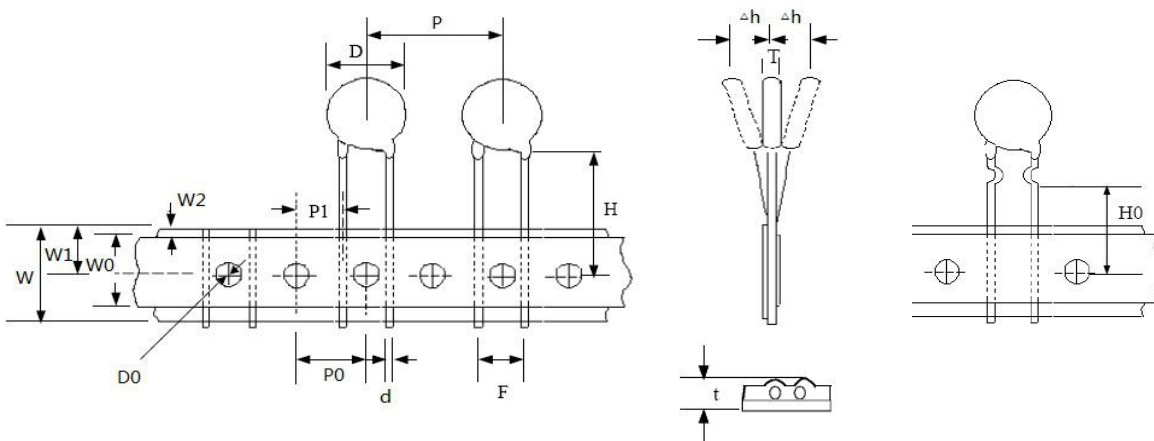

Unit: mm

Symbol	Parameter	Nominal dimensions			Tolerance
F	Lead spacing	5	7.5	10	± 1
P	Component pitch	12.7	25.4	25.4	± 1
P0	Sprocket hole pitch	12.7			± 0.3
P1	Lead location	3.85	8.95	7.7	± 1
W	Carrier tape width	18			+1/-0.5
W0	Adhesive tape width	min 12.5			-
W1	Sprocket hole position	9			± 0.5
W2	Adhesive tape position	max. 3			-
D0	Sprocket hole diameter	4			± 0.2
H	Height between component and tape centre	18			± 1.5
H0	Lead wire clinch height	16			± 1
Δh	Component alignment	0			± 2
t	Total tape thickness	max. 0.9			-

Packagin

(1) Bulk Packing

Diameter	Quantity (pcs / bag)
Ø5	1000
Ø8	1000
Ø10	1000
Ø13	500
Ø15	250
Ø20	200
Ø25	50
Ø30	30

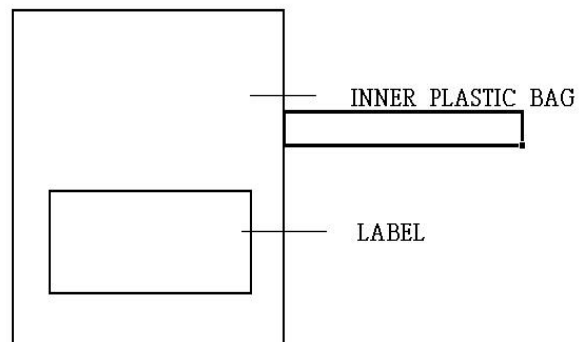

(2) Reel Packing

Diameter	C (mm)	B (mm)	A (mm)	E (mm)	Quantity (pcs / reel)
Ø5	340±5	76±2	31±2	40±1	2500
Ø8				55±1	1500
Ø10					1500
Ø13					750
Ø15					750
Ø20					500

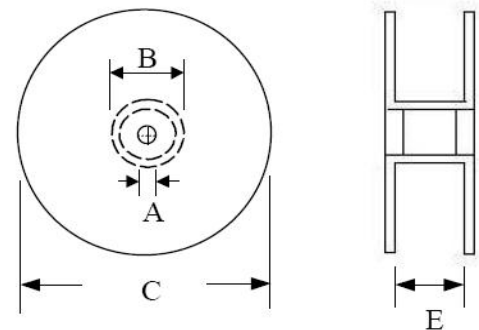

(3) Ammo Packing

Diameter	A (mm)	B (mm)	C (mm)	Quantity (pcs / box)
Ø5	330±10	260±10	50±5	1000
Ø8				1000
Ø10				1000
Ø13				500
Ø15				500
Ø20				500

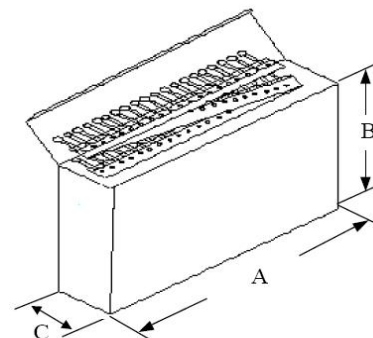

Storage conditions of products

∴ Storage conditions:

1. Storage Temperature: -10°C ~ +40°C
2. Relative Humidity: ≤75% RH
3. Keep away from corrosive atmosphere and sunlight.

∴ Shelf life: 1 year

Disc/Block Type Varistor for Lightning Protection

Product No.: MVA*

Features:

- ◆ Wide operating voltage range
- ◆ Excellent clamping ratio
- ◆ Bidirectional and symmetrical V/I characteristics
- ◆ Large withstanding surge current capability
- ◆ Excell thermal stable ability
- ◆ Operation temperature range: $-40^{\circ}\text{C} \sim +85^{\circ}\text{C}$
- ◆ Storage temperature range: $-40^{\circ}\text{C} \sim +110^{\circ}\text{C}$

Applications:

- ◆ Power distribution
- ◆ Communication power
- ◆ Antenna
- ◆ New energy
- ◆ Lighting
- ◆ Rail traffic system
- ◆ Industrial equipment

Part Number Code

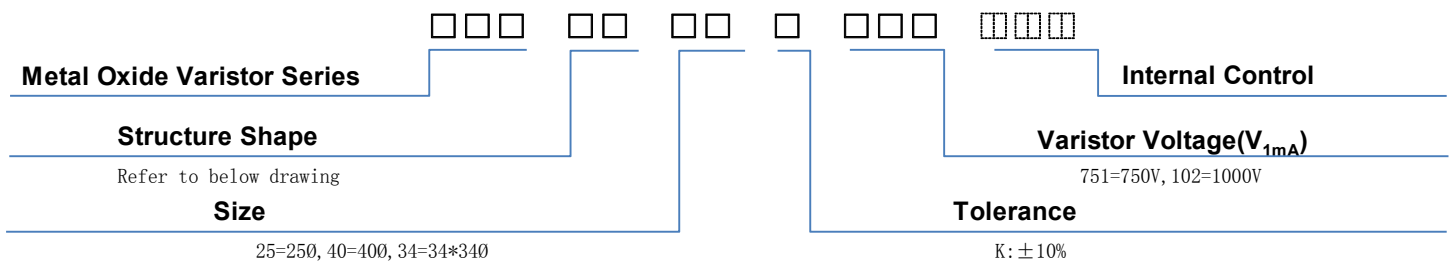

*Structure Shape:

Silver Disc (1D Type)



Welding (1W Type)



Plastic Case (1B Type)



Epoxy (1C Type)



Multi-Chip Module (*W & *C Type)



Note: * is parallel structure of quantity discs.

Besides The Above Standard Characteristic Product, We Have Some Special Types And Can Provide The Flexible Design According To Your Needs As Well. Please inquire to our sales people for other spec.

25mm & 32mm Series

Part No.	Varistor Voltage (±10%)	Max. Continuous Voltage		Max. Clamping Voltage (8/20µs)		Surge Operating Duty Test (8/20µs)		Max. Energy (2ms)	Rated Power	Reference Capacitance @1KHz
	V _{1mA} (V)	V _{AC(ms)} (V)	V _{DC} (V)	V _p (V)	I _p (A)	I _{max} (KA)	I _n (KA)	W _{max} (J)	P (W)	C _p (pF)
MVA□□25K201	200	130	170	340	150	20	10	128	1.0	2200
MVA□□25K221	220	140	180	365	150	20	10	135	1.0	2000
MVA□□25K241	240	150	200	395	150	20	10	146	1.0	1900
MVA□□25K271	270	175	225	455	150	20	10	170	1.0	1600
MVA□□25K361	360	230	300	595	150	20	10	190	1.0	1300
MVA□□25K391	390	250	320	650	150	20	10	210	1.0	1100
MVA□□25K431	430	275	350	710	150	20	10	220	1.0	1000
MVA□□25K471	470	300	385	775	150	20	10	225	1.0	950
MVA□□25K511	510	320	415	845	150	20	10	230	1.0	900
MVA□□25K561	560	350	450	930	150	20	10	235	1.0	800
MVA□□25K621	620	385	505	1025	150	20	10	240	1.0	700
MVA□□25K681	680	420	560	1120	150	20	10	250	1.0	650
MVA□□25K751	750	460	615	1240	150	20	10	275	1.0	600
MVA□□25K781	780	485	640	1290	150	20	10	290	1.0	550
MVA□□25K821	820	510	670	1355	150	20	10	300	1.0	520
MVA□□25K911	910	550	745	1500	150	20	10	340	1.0	500
MVA□□25K951	950	575	765	1570	150	20	10	355	1.0	450
MVA□□25K102	1000	625	825	1650	150	20	10	375	1.0	430
MVA□□25K112	1100	680	895	1815	150	20	10	390	1.0	400
MVA□□25K122	1200	750	980	2000	150	20	10	420	1.0	370
MVA□□32K201	200	130	170	340	200	30	15	210	1.2	3900
MVA□□32K221	220	140	180	365	200	30	15	225	1.2	3500
MVA□□32K241	240	150	200	395	200	30	15	240	1.2	3300
MVA□□32K271	270	175	225	455	200	30	15	250	1.2	2800
MVA□□32K361	360	230	300	595	200	30	15	300	1.2	2200
MVA□□32K391	390	250	320	650	200	30	15	330	1.2	2000
MVA□□32K431	430	275	350	710	200	30	15	360	1.2	1800
MVA□□32K471	470	300	385	775	200	30	15	405	1.2	1700
MVA□□32K511	510	320	415	845	200	30	15	430	1.2	1600
MVA□□32K561	560	350	450	930	200	30	15	470	1.2	1400
MVA□□32K621	620	385	505	1025	200	30	15	550	1.2	1250
MVA□□32K681	680	420	560	1120	200	30	15	600	1.2	1150
MVA□□32K751	750	460	615	1240	200	30	15	660	1.2	1100
MVA□□32K781	780	485	640	1290	200	30	15	680	1.2	1050
MVA□□32K821	820	510	670	1355	200	30	15	550	1.2	950
MVA□□32K911	910	550	745	1500	200	30	15	620	1.2	900
MVA□□32K951	950	575	765	1570	200	30	15	660	1.2	850
MVA□□32K102	1000	625	825	1650	200	30	15	690	1.2	800
MVA□□32K112	1100	680	895	1815	200	30	15	760	1.2	750
MVA□□32K122	1200	750	980	2000	200	30	15	800	1.2	650
MVA□□32K182	1800	1000	1465	2970	200	25	12.5	1200	1.2	450

34mm Series

Part No.	Varistor Voltage (±10%)	Max. Continuous Voltage		Max. Clamping Voltage (8/20µs)		Surge Operating Duty Test (8/20µs)		Max. Energy (2ms)	Rated Power	Reference Capacitance @1KHz
	V _{1mA} (V)	V _{AC(ms)} (V)	V _{DC} (V)	V _p (V)	I _p (A)	I _{max} (KA)	I _n (KA)	W _{max} (J)	P (W)	C _p (pF)
MVA1□34K201	200	130	170	340	300	40	20	310	1.4	5600
MVA1□34K221	220	140	180	365	300	40	20	340	1.4	5000
MVA1□34K241	240	150	200	395	300	40	20	360	1.4	4800
MVA1□34K271	270	175	225	455	300	40	20	400	1.4	4100
MVA1□34K361	360	230	300	595	300	40	20	460	1.4	3200
MVA1□34K391	390	250	320	650	300	40	20	490	1.4	2800
MVA1□34K431	430	275	350	710	300	40	20	550	1.4	2600
MVA1□34K471	470	300	385	775	300	40	20	595	1.4	2400
MVA1□34K511	510	320	415	845	300	40	20	640	1.4	2300
MVA1□34K561	560	350	450	930	300	40	20	710	1.4	2000
MVA1□34K621	620	385	505	1025	300	40	20	800	1.4	1800
MVA1□34K681	680	420	560	1120	300	40	20	910	1.4	1700
MVA1□34K751	750	460	615	1240	300	40	20	1000	1.4	1600
MVA1□34K781	780	485	640	1290	300	40	20	1030	1.4	1500
MVA1□34K821	820	510	670	1355	300	40	20	860	1.4	1400
MVA1□34K911	910	550	745	1500	300	40	20	960	1.4	1300
MVA1□34K951	950	575	765	1570	300	40	20	1000	1.4	1200
MVA1□34K102	1000	625	825	1650	300	40	20	1050	1.4	1150
MVA1□34K112	1100	680	895	1815	300	40	20	1200	1.4	1050
MVA1□34K122	1200	750	980	2000	300	40	20	1310	1.4	950
MVA1□34K182	1800	1000	1465	2970	300	30	15	1800	1.4	700
MVA2□34K201	200	130	170	340	500	70	40	410	1.6	14040
MVA2□34K221	220	140	180	365	500	70	40	450	1.6	12760
MVA2□34K241	240	150	200	395	500	70	40	490	1.6	11700
MVA2□34K271	270	175	225	455	500	70	40	550	1.6	10400
MVA2□34K361	360	230	300	595	500	70	40	730	1.6	7800
MVA2□34K391	390	250	320	650	500	70	40	800	1.6	7200
MVA2□34K431	430	275	350	710	500	70	40	860	1.6	6600
MVA2□34K471	470	300	385	775	500	70	40	950	1.6	6100
MVA2□34K511	510	320	415	845	500	70	40	1000	1.6	5800
MVA2□34K561	560	350	450	930	500	70	40	1100	1.6	5100
MVA2□34K621	620	385	505	1025	500	70	40	1200	1.6	4600
MVA2□34K681	680	420	560	1120	500	70	40	1500	1.6	4300
MVA2□34K751	750	460	615	1240	500	70	40	1650	1.6	4100
MVA2□34K781	780	485	640	1290	500	70	40	1700	1.6	3800
MVA2□34K821	820	510	670	1355	500	70	40	1350	1.6	3600
MVA2□34K911	910	550	745	1500	500	70	40	1500	1.6	3300
MVA2□34K951	950	575	765	1570	500	70	40	1560	1.6	3000
MVA2□34K102	1000	625	825	1650	500	70	40	1650	1.6	2900
MVA2□34K112	1100	680	895	1815	500	70	40	1800	1.6	2700
MVA2□34K122	1200	750	980	2000	500	70	40	2000	1.6	2500

34mm & 40mm Series

Part No.	Varistor Voltage (±10%)	Max. Continuous Voltage		Max. Clamping Voltage (8/20µs)		Surge Operating Duty Test (8/20µs)		Max. Energy (2ms)	Rated Power	Reference Capacitance @1KHz
	V _{1mA} (V)	V _{AC(ms)} (V)	V _{DC} (V)	V _p (V)	I _p (A)	I _{max} (KA)	I _n (KA)	W _{max} (J)	P (W)	C _p (pF)
MVA3□34K431	430	275	350	710	800	100		1600		
MVA3□34K511	510	320	415	845	800	100		1900		
MVA3□34K621	620	385	505	1025	800	100		2400		
MVA3□34K681	680	420	560	1120	800	100		2700		
MVA4□34K431	430	275	350	710	1000	120		2100		
MVA4□34K511	510	320	415	845	1000	120		2500		
MVA4□34K621	620	385	505	1025	1000	120		3200		
MVA4□34K681	680	420	560	1120	1000	120		3600		
MVA□□40K201	200	130	170	340	300	40	20	310	1.4	6000
MVA□□40K221	220	140	180	365	300	40	20	340	1.4	5500
MVA□□40K241	240	150	200	395	300	40	20	360	1.4	5000
MVA□□40K271	270	175	225	455	300	40	20	400	1.4	4500
MVA□□40K361	360	230	300	595	300	40	20	460	1.4	3500
MVA□□40K391	390	250	320	650	300	40	20	490	1.4	3000
MVA□□40K431	430	275	350	710	300	40	20	550	1.4	2800
MVA□□40K471	470	300	385	775	300	40	20	595	1.4	2600
MVA□□40K511	510	320	415	845	300	40	20	640	1.4	2500
MVA□□40K561	560	350	450	930	300	40	20	710	1.4	2200
MVA□□40K621	620	385	505	1025	300	40	20	800	1.4	2000
MVA□□40K681	680	420	560	1120	300	40	20	910	1.4	1800
MVA□□40K751	750	460	615	1240	300	40	20	1000	1.4	1700
MVA□□40K781	780	485	640	1290	300	40	20	1030	1.4	1600
MVA□□40K821	820	510	670	1355	300	40	20	860	1.4	1500
MVA□□40K911	910	550	745	1500	300	40	20	960	1.4	1400
MVA□□40K951	950	575	765	1570	300	40	20	1000	1.4	1300
MVA□□40K102	1000	625	825	1650	300	40	20	1050	1.4	1200
MVA□□40K112	1100	680	895	1815	300	40	20	1200	1.4	1100
MVA□□40K122	1200	750	980	2000	300	40	20	1310	1.4	1000
MVA□□40K182	1800	1000	1465	2970	300	30	15	1800	1.4	750

53mm Series

Part No.	Varistor Voltage (±10%)	Max. Continuous Voltage		Max. Clamping Voltage (8/20µs)		Surge Operating Duty Test (8/20µs)		Max. Energy (2ms)	Rated Power	Reference Capacitance @1KHz
	V _{1mA} (V)	V _{AC(ms)} (V)	V _{DC} (V)	V _p (V)	I _p (A)	I _{max} (KA)	I _n (KA)	W _{max} (J)	P (W)	C _p (pF)
MVA□□53K431	430	275	350	710	500	70	30	860	1.6	6600
MVA□□53K471	470	300	385	775	500	70	30	930	1.6	6100
MVA□□53K511	510	320	420	845	500	70	30	1000	1.6	5600
MVA□□53K561	560	350	460	930	500	70	30	1100	1.6	5100
MVA□□53K621	620	385	505	1025	500	70	30	1200	1.6	4600
MVA□□53K681	680	420	560	1120	500	70	30	1500	1.6	4300
MVA□□53K751	750	460	615	1240	500	70	30	1650	1.6	3900
MVA□□53K821	820	510	670	1355	500	70	30	1680	1.6	3600
MVA□□53K911	910	550	745	1500	500	70	30	1700	1.6	3300
MVA□□53K102	1000	625	825	1650	500	70	30	1750	1.6	3000
MVA□□53K112	1100	680	895	1815	500	70	30	1800	1.6	2600
MVA□□53K122	1200	750	970	2000	500	70	30	2000	1.6	2400

80mm Series

Part No.	Varistor Voltage (±10%)	Max. Continuous Voltage		Max. Clamping Voltage (8/20µs)		Max. Surge Current (8/20µs)	Max. Energy (2ms)
	V _{1mA} (V)	V _{AC(ms)} (V)	V _{DC} (V)	V _p (V)	I _p (A)	I _{max} (KA)	W _{max} (J)
MVA1B80K431	430	275	350	710	800	100	1400
MVA1B80K471	470	300	385	775	800	100	1500
MVA1B80K511	510	320	420	845	800	100	1600
MVA1B80K561	560	350	460	925	800	100	1800
MVA1B80K621	620	385	505	1025	800	100	2000
MVA1B80K681	680	420	560	1120	800	100	2200
MVA1B80K821	820	510	670	1355	800	100	2900
MVA1B80K911	910	550	745	1500	800	100	3100
MVA1B80K102	1000	625	825	1650	800	100	3400
MVA1B80K112	1100	680	895	1815	800	100	3600
MVA1B80K122	1200	750	970	2000	800	100	4000

Thermally Protected Varistor Series

Product No.: MVT*

Features:

- ◆ Two-terminal or Three-terminal thermally protected metal oxide varistor, Three-terminal type is available for failure indication.
- ◆ Working voltage: 130V-750Vac
- ◆ Operation temperature range: -40°C ~ +85°C
Storage temperature range: -40°C ~ +110°C
- ◆ Suitable for wave flow soldering

Applications:

- ◆ Smart meter
- ◆ Power supplies
- ◆ TVSS modules
- ◆ Lighting products
- ◆ Photovoltaic industry
- ◆ Communication products
- ◆ Uninterruptible power supplies

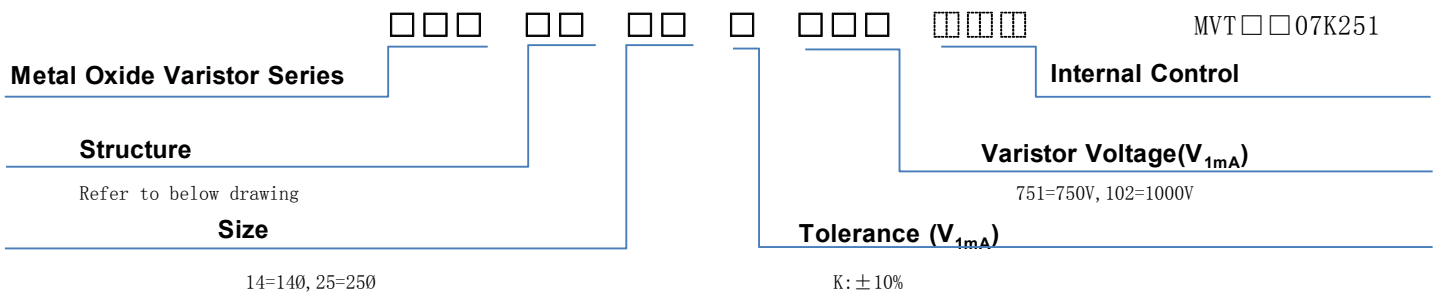

*Structure and Dimensions

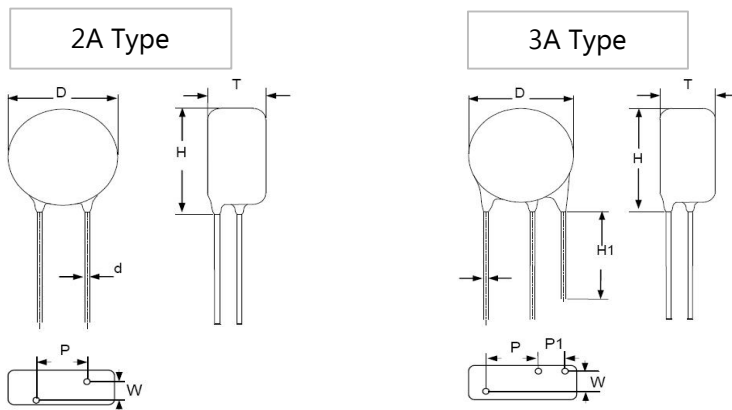

Lead TYPE	Series	D	P	P1	H	H1	d
Two-terminal (2A Type)	MVT14K201~122	15.5-18.5	7.5 ± 1	-	18.5-24	-	0.8 ± 0.05
	MVT20K201~681	19.5-23.5			21.5-27		1.0 ± 0.05
	MVT20K751~122						
Three-terminal (3A Type)	MVT14K201~122	15.5-18.5		4.0-6.0	18.5-24	7.0-18	0.8 ± 0.05
	MVT20K201~681	19.5-23.5			21.5-27	12.5-18	1.0 ± 0.05
	MVT20K751~122						

* "W" and "T" Dimensions please refer to electrical characteristics.

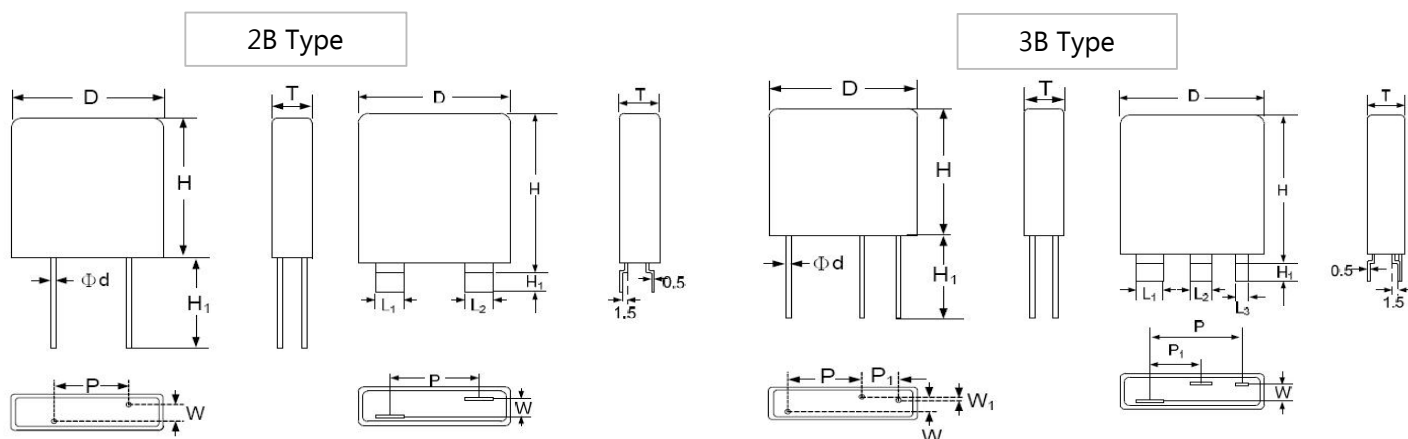

Lead TYPE	Series	D	P	P1	H	H1	d/L1/L2	L3
Two-terminal (2B Type)	MVT25*	33 ± 1	10 ± 1	-	33.5 ± 1	min. 15	1 ± 0.05	-
	MVT32*	40 ± 1			42 ± 1		1.5 ± 0.05	-
	MVT34*		21.5 ± 2		max. 42	max. 8	6 ± 0.1	-
Three-terminal (3B Type)	MVT25*	33 ± 1	15 ± 1	5 ± 1	33.5 ± 1	min. 15	1 ± 0.05	-
	MVT32*	40 ± 1		8 ± 1			42 ± 1	1.5 ± 0.05
	MVT34*		23.5 ± 2	11 ± 2	max. 42	max. 8	6 ± 0.1	3 ± 0.1

*Lead Configuration

Two-terminal(2A/2B Type)

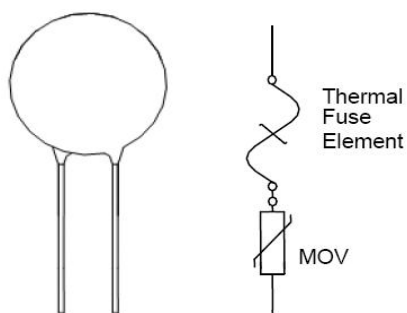

Three-terminal(3A/3B Type)

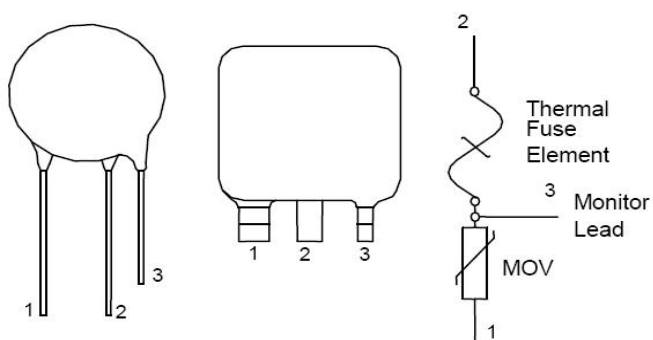

*Warehouse Storage Conditions of Products

1. Storage temperature: $-10^{\circ}\text{C} \sim +40^{\circ}\text{C}$
2. Relative humidity: $\leq 75\% \text{ RH}$
3. Keep away from corrosive atmosphere and sunlight
4. Period of storage: 1 year

*Electrical Characteristics

14mm Series

Part No.	Varistor Voltage (@1mA DC) 10%	Max. Continuous Voltage		Max. Clamping Voltage (8/20 μ s)		Max. Surge Current (8/20 μ s)	Nominal Discharge Current (8/20 μ s)	Max. Energy (10/1000 μ s)	Rated Power	Reference Capacitance @1KHz	Dimension	
	V_{1mA}	$V_{AC(ms)}$	V_{DC}	V_p	I_p	I_{max}	I_n	W_{max}	P	C_p	T_{max}	$W_{\pm 1}$
	(V)	(V)	(V)	(V)	(A)	(KA)	(KA)	(J)	(W)	(pF)	(mm)	
MVT□□14K201	200	130	170	340	50.0	6	3	77	0.60	700	8.8	3.0
MVT□□14K221	220	140	180	365	50.0	6	3	86	0.60	640	8.9	3.1
MVT□□14K241	240	150	200	395	50.0	6	3	94	0.60	580	9.1	3.3
MVT□□14K271	270	175	225	455	50.0	6	3	110	0.60	520	9.3	3.5
MVT□□14K301	300	195	250	500	50.0	6	3	118	0.60	480	9.0	3.2
MVT□□14K331	330	215	275	550	50.0	6	3	127	0.60	450	9.1	3.3
MVT□□14K361	360	230	300	595	50.0	6	3	137	0.60	430	9.3	3.5
MVT□□14K391	390	250	320	650	50.0	6	3	154	0.60	390	9.5	3.6
MVT□□14K431	430	275	350	710	50.0	6	3	170	0.60	370	9.2	3.4
MVT□□14K471	470	300	385	775	50.0	6	3	192	0.60	320	9.3	3.5
MVT□□14K511	510	320	410	845	50.0	6	3	209	0.60	290	9.5	3.7
MVT□□14K561	560	350	450	930	50.0	6	3	220	0.60	260	9.7	3.9
MVT□□14K621	620	395	510	1025	50.0	6	3	231	0.60	240	10.0	4.1
MVT□□14K681	680	420	560	1120	50.0	6	3	242	0.60	230	10.3	4.4
MVT□□14K751	750	465	615	1240	50.0	6	3	247	0.60	220	10.6	4.7
MVT□□14K781	780	485	640	1290	50.0	6	3	260	0.60	200	10.1	4.3
MVT□□14K821	820	510	670	1355	50.0	6	3	270	0.60	180	10.2	4.5
MVT□□14K911	910	550	745	1500	50.0	6	3	280	0.60	170	10.6	4.8
MVT□□14K951	950	575	765	1570	50.0	6	3	290	0.60	160	10.7	4.9
MVT□□14K102	1000	625	825	1650	50.0	6	3	305	0.60	150	10.9	5.1
MVT□□14K112	1100	680	895	1815	50.0	6	3	340	0.60	140	11.2	5.4
MVT□□14K122	1200	750	980	2000	50.0	6	-	350	0.60	130	11.6	5.8

20mm Series

Part No.	Varistor Voltage (@1mA DC 10%)	Max. Continuous Voltage		Max. Clamping Voltage (8/20µs)		Max. Surge Current (8/20µs)	Nominal Discharge Current (8/20µs)	Max. Energy (10/1000 µs)	Rated Power	Reference Capacitance @1KHz	Dimension	
	V _{1mA}	V _{AC(ms)}	V _{DC}	V _p	I _p	I _{max}	I _n	W _{max}	P	C _p	T _{max}	W±1
	(V)	(V)	(V)	(V)	(A)	(KA)	(KA)	(J)	(W)	(pF)	(mm)	
MVT□□20K201	200	130	170	340	100	10	3	140	1.00	1460	10.2	3.0
MVT□□20K221	220	140	180	365	100	10	3	155	1.00	1320	10.3	3.1
MVT□□20K241	240	150	200	395	100	10	3	170	1.00	1200	10.5	3.3
MVT□□20K271	270	175	225	455	100	10	3	190	1.00	1100	10.7	3.5
MVT□□20K301	300	195	250	500	100	10	3	205	1.00	1000	10.4	3.2
MVT□□20K331	330	215	275	550	100	10	3	215	1.00	950	10.5	3.3
MVT□□20K361	360	230	300	595	100	10	3	225	1.00	900	10.7	3.5
MVT□□20K391	390	250	320	650	100	10	3	240	1.00	800	10.9	3.6
MVT□□20K431	430	275	350	710	100	10	3	270	1.00	700	10.6	3.4
MVT□□20K471	470	300	385	775	100	10	3	350	1.00	620	10.7	3.5
MVT□□20K511	510	320	410	845	100	10	3	386	1.00	530	10.9	3.7
MVT□□20K561	560	350	450	930	100	10	3	400	1.00	480	11.1	3.9
MVT□□20K621	620	395	510	1025	100	10	3	425	1.00	450	11.4	4.1
MVT□□20K681	680	420	560	1120	100	10	3	455	1.00	440	11.7	4.4
MVT□□20K751	750	465	615	1240	100	10	3	509	1.00	420	12.0	4.7
MVT□□20K781	780	485	640	1290	100	10	3	515	1.00	400	11.5	4.3
MVT□□20K821	820	510	670	1355	100	10	3	475	1.00	390	11.6	4.5
MVT□□20K911	910	550	745	1500	100	10	3	509	1.00	360	12.0	4.8
MVT□□20K951	950	575	765	1570	100	10	3	530	1.00	340	12.1	4.9
MVT□□20K102	1000	625	825	1650	100	10	3	560	1.00	330	12.3	5.1
MVT□□20K112	1100	680	895	1815	100	10	3	610	1.00	310	12.6	5.4
MVT□□20K122	1200	750	980	2000	100	10	-	620	1.00	290	13.0	5.8

25mm Series

Part No.	Varistor Voltage (@1mA DC) 10%	Max. Continuous Voltage		Max. Clamping Voltage (8/20 μ s)		Max. Surge Current (8/20 μ s)	Nominal Discharge Current (8/20 μ s)	Max. Energy (10/1000 μ s)	Rated Power	Reference Capacitance @1KHz	Dimension		
	V _{1mA}	V _{AC(ms)}	V _{DC}	V _p	I _p	I _{max}	I _n	W _{max}	P	C _p	T _{max}	W1 \pm 1	W \pm 1
	(V)	(V)	(V)	(V)	(A)	(KA)	(KA)	(J)	(W)	(pF)	(mm)		
MVT□□25K201	200	130	170	340	150	20	5	210	1.0	2200	15	1.9	5.6
MVT□□25K221	220	140	180	360	150	20	5	230	1.0	2000			5.8
MVT□□25K241	240	150	200	395	150	20	5	255	1.0	1900			6.0
MVT□□25K271	270	175	225	455	150	20	5	285	1.0	1600			6.3
MVT□□25K301	300	195	250	500	150	20	5	310	1.0	1500			5.8
MVT□□25K331	330	215	275	550	150	20	5	325	1.0	1400			6.1
MVT□□25K361	360	230	300	595	150	20	5	340	1.0	1300			6.3
MVT□□25K391	390	250	320	650	150	20	5	360	1.0	1100			6.5
MVT□□25K431	430	275	350	710	150	20	5	440	1.0	1000			5.7
MVT□□25K471	470	300	385	775	150	20	5	490	1.0	950			5.8
MVT□□25K511	510	320	410	845	150	20	5	530	1.0	900			6.0
MVT□□25K561	560	350	450	930	150	20	5	560	1.0	800	19	1.9	6.3
MVT□□25K621	620	395	510	1020	150	20	5	590	1.0	700			6.6
MVT□□25K681	680	420	560	1120	150	20	5	620	1.0	650			6.9
MVT□□25K751	750	465	615	1235	150	20	5	630	1.0	600			7.2
MVT□□25K781	780	485	640	1290	150	20	5	675	1.0	550			6.4
MVT□□25K821	820	510	670	1355	150	20	5	690	1.0	520			6.5
MVT□□25K911	910	550	745	1500	150	20	5	715	1.0	500			6.8
MVT□□25K951	950	575	765	1570	150	20	5	740	1.0	450			7.0
MVT□□25K102	1000	625	825	1650	150	20	5	770	1.0	430			7.2
MVT□□25K112	1100	680	895	1815	150	20	5	840	1.0	400			7.5
MVT□□25K122	1200	750	980	2000	150	20	-	910	1.0	380			7.8

32mm Series

Part No.	Varistor Voltage (@1mA DC) 10%	Max. Continuous Voltage			Max. Clamping Voltage (8/20 μ s)		Max. Surge Current (8/20 μ s)	Nominal Discharge Current (8/20 μ s)	Max. Energy (10/1000 μ s)	Rated Power	Reference Capacitance @1KHz	Dimension	
		V_{1mA}	$V_{AC(ms)}$	V_{DC}	V_p	I_p	I_{max}	I_n	W_{max}	P	C_p	Tmax.	W \pm 1
		(V)	(V)	(V)	(V)	(A)	(KA)	(KA)	(J)	(W)	(pF)	(mm)	
MVT□□32K201	200	130	170	340	200	25	10	295	1.2	3900	16	6.2	
MVT□□32K221	220	140	180	360	200	25	10	315	1.2	3500		6.4	
MVT□□32K241	240	150	200	395	200	25	10	340	1.2	3300		6.6	
MVT□□32K271	270	175	225	455	200	25	10	360	1.2	28200		6.9	
MVT□□32K301	300	195	250	500	200	25	10	380	1.2	2600		6.4	
MVT□□32K331	330	215	275	550	200	25	10	400	1.2	2400		6.7	
MVT□□32K361	360	230	300	595	200	25	10	420	1.2	2200		6.9	
MVT□□32K391	390	250	320	650	200	25	10	465	1.2	2000		7.1	
MVT□□32K431	430	275	350	710	200	25	10	505	1.2	1800		6.3	
MVT□□32K471	470	300	385	775	200	25	10	570	1.2	1700		6.4	
MVT□□32K511	510	320	410	845	200	25	10	605	1.2	1600		6.6	
MVT□□32K561	560	350	450	930	200	25	10	660	1.2	1400	20	6.9	
MVT□□32K621	620	395	510	1020	200	25	10	770	1.2	1250		7.2	
MVT□□32K681	680	420	560	1120	200	25	10	840	1.2	1150		7.5	
MVT□□32K751	750	465	615	1235	200	25	10	925	1.2	1100		7.8	
MVT□□32K781	780	485	640	1290	200	25	10	955	1.2	1050		7.0	
MVT□□32K821	820	510	670	1355	200	25	10	770	1.2	950		7.1	
MVT□□32K911	910	550	745	1500	200	25	10	870	1.2	900		7.4	
MVT□□32K951	950	575	765	1570	200	25	10	925	1.2	850		7.6	
MVT□□32K102	1000	625	825	1650	200	25	10	965	1.2	800		7.8	
MVT□□32K112	1100	680	895	1815	200	25	10	1065	1.2	750		8.1	
MVT□□32K122	1200	750	980	2000	200	25	-	1120	1.2	650	8.4		

34mm Series

Part No.	Varistor Voltage (@1mA DC) 10%	Max. Continuous Voltage			Max. Clamping Voltage (8/20 μ s)		Max. Surge Current (8/20 μ s)	Nominal Discharge Current (8/20 μ s)	Max. Energy (10/1000 μ s)	Rated Power	Reference Capacitance @1KHz	Dimension	
		V_{1mA}	$V_{AC(ms)}$	V_{DC}	V_p	I_p						Tmax.	W \pm 1
		(V)	(V)	(V)	(V)	(A)							
MVT□□34K201	200	130	170	340	300	40	20	435	1.4	5600	16	6.2	
MVT□□34K221	220	140	180	360	300	40	20	480	1.4	5000		6.4	
MVT□□34K241	240	150	200	395	300	40	20	505	1.4	4800		6.6	
MVT□□34K271	270	175	225	455	300	40	20	560	1.4	4100		6.9	
MVT□□34K301	300	195	250	500	300	40	20	590	1.4	3800		6.4	
MVT□□34K331	330	215	275	550	300	40	20	620	1.4	3500		6.7	
MVT□□34K361	360	230	300	595	300	40	20	645	1.4	3200		6.9	
MVT□□34K391	390	250	320	650	300	40	20	690	1.4	2800		7.1	
MVT□□34K431	430	275	350	710	300	40	20	770	1.4	2600		6.3	
MVT□□34K471	470	300	385	775	300	40	20	835	1.4	2400		6.4	
MVT□□34K511	510	320	410	845	300	40	20	900	1.4	2300		6.6	
MVT□□34K561	560	350	450	930	300	40	20	995	1.4	2000	20	6.9	
MVT□□34K621	620	395	510	1020	300	40	20	1120	1.4	1800		7.2	
MVT□□34K681	680	420	560	1120	300	40	20	1275	1.4	1700		7.5	
MVT□□34K751	750	465	615	1235	300	40	20	1400	1.4	1600		7.8	
MVT□□34K781	780	485	640	1290	300	40	20	1445	1.4	1500		7.0	
MVT□□34K821	820	510	670	1355	300	40	20	1205	1.4	1400		7.1	
MVT□□34K911	910	550	745	1500	300	40	20	1345	1.4	1300		7.4	
MVT□□34K951	950	575	765	1570	300	40	20	1400	1.4	1200		7.6	
MVT□□34K102	1000	625	825	1650	300	40	20	1470	1.4	1150		7.8	
MVT□□34K112	1100	680	895	1815	300	40	20	1610	1.4	1050		8.1	
MVT□□34K122	1200	750	980	2000	300	40	-	1750	1.4	950		8.4	

PTC Temperature Sensor

Product No.: PT*

Features:

- ◆ Small size
- ◆ Very fast reaction time
- ◆ Wide range of protection temperatures
- ◆ Stable over a long life
- ◆ Operation temperature range: 0 ~ Ts+25 °C

Applications:

- ◆ Lighting applications
- ◆ Home appliances
- ◆ Automotive electronics
- ◆ Motor Windings

Part Number Code

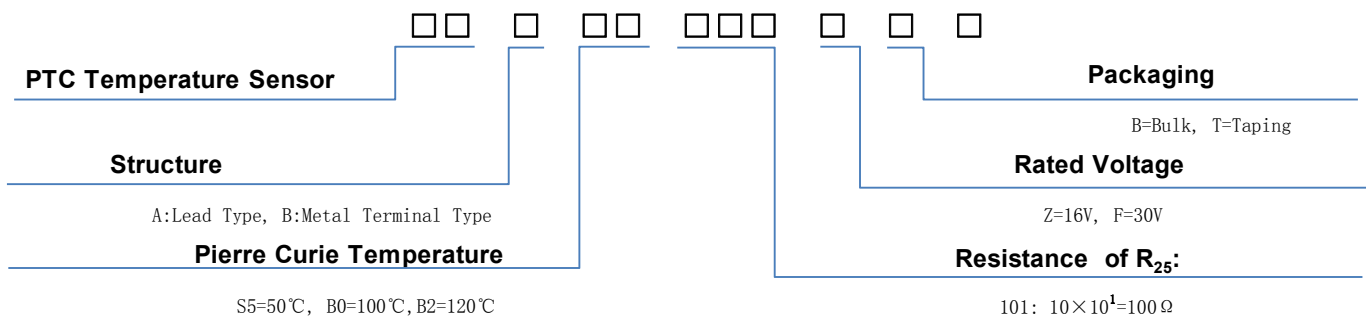

* Taping specification is applied to PTA series only

Structure and Dimensions

(1) PTA: (Lead Type)

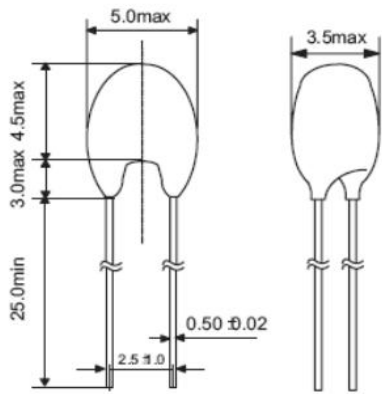

(2) PTB: (Metal Terminal Type)

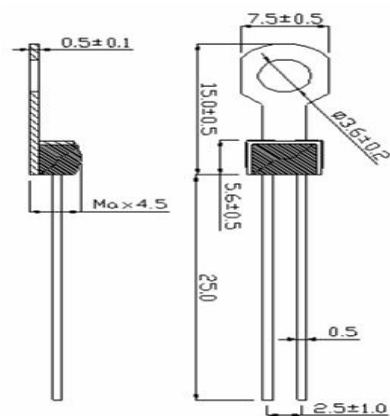

Unit: mm

Taping Information

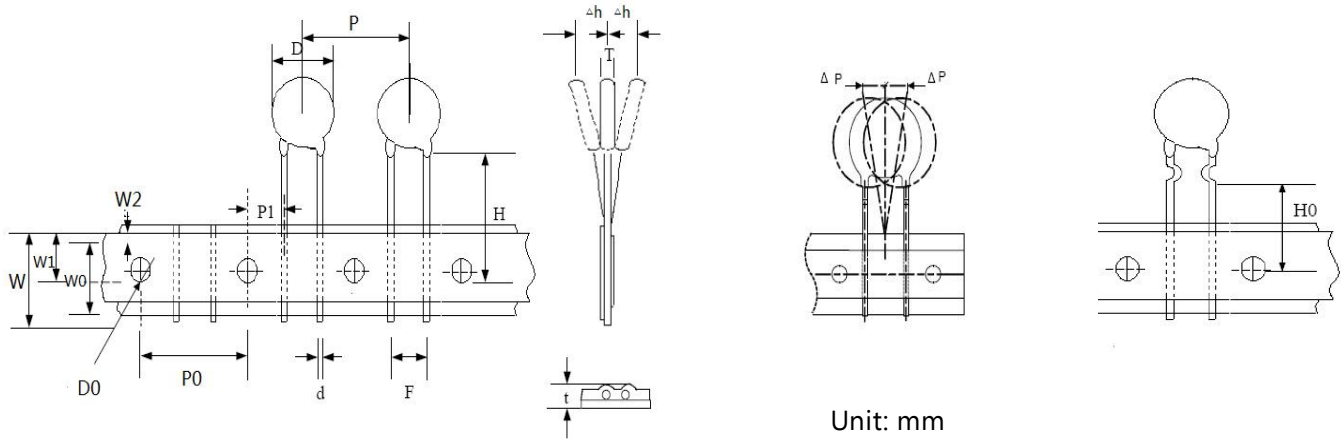

Unit: mm

Symbol	Parameter	Nominal	Symbol	Parameter	Nominal
F	Lead spacing	2.5±1	W	Carrier tape width	18+1/-0.5
P	Component pitch	12.7±1	W0	Adhesive tape width	12±1
P0	Sprocket hole pitch	12.7±0.3	W1	Sprocket hole position	9±1
P1	Lead location	5±1	W2	Adhesive tape position	Max.3
H	Height between component and tape centre	18±1	D0	Sprocket hole diameter	4±0.2
			Δh	Component alignment	Max.1.5
			ΔP	Component alignment	Max.1
H0	Lead wire clinch height	16±1	t	Total tape thickness	Max.0.9

Specifications:

Part No.	Max. Voltage (Vdc)	Max. Current (mA)	Pierre Curie Temperature	Sensing Temp.	Nominal Resistance at 25°C	Resistance Value (at Sensing Temp.) -10°C	Resistance Value (at Sensing Temp.)
	Vdc	mA	°C	°C	Ω	max Ω	min Ω
PT □ S4101 ◇ *	16 / 30	100	40	60	100 max.	330	470
PT □ S5101 ◇ *			50	70			
PT □ S6101 ◇ *			60	80			
PT □ S7101 ◇ *			70	90			
PT □ S8101 ◇ *			80	100			
PT □ S9101 ◇ *			90	110			
PT □ B0101 ◇ *			100	120	300 max.	1.5K	2.2K
PT □ S4101 ◇ *			40	60			
PT □ S5301 ◇ *			50	70			
PT □ S6301 ◇ *			60	80			
PT □ S7301 ◇ *			70	90			
PT □ S8301 ◇ *			80	100			
PT □ S9301 ◇ *			90	110			
PT □ B0301 ◇ *			100	120			

Note: 1. □ means A(Lead Type) or B(Metal Terminal Type)

2. ◇ means Z(16V) or F(30V)

3. * means Packaging(B=Bulk or T=Taping)

Switching applications

Product No.: PTT*

Features:

- ◆ Small size
- ◆ For frequent switching
- ◆ Low, medium and high resistance ratings
- ◆ Stable over a long life
- ◆ Operation temperature range: 0 ~ +60 °C (V=Vmax), -25 ~ +125 °C (V=0)

Applications:

- ◆ Electronic ballast for lamps, switching
- ◆ Energy saving lamp

Part Number Code

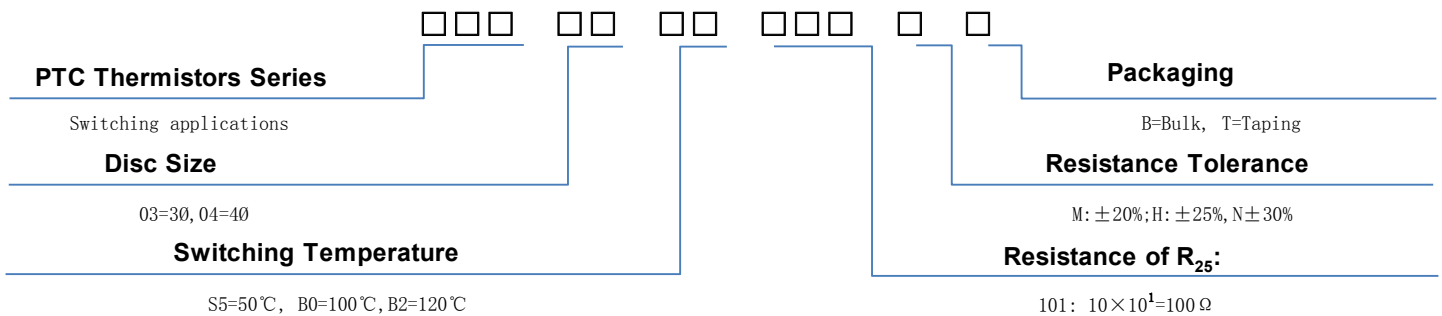

Structure and Dimensions

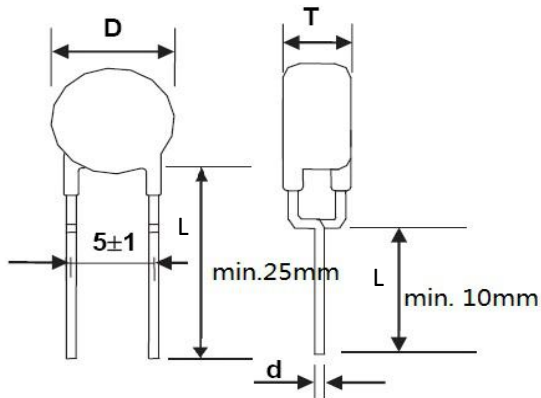

Packing:

L	Part No.	Quantity (pcs)		
		bag	box (small)	box (big)
L ≤ 10mm	PTT03*	1000	10000	50000
	PTT04*	1000	10000	50000
	PTT05*	1000	6000	36000
	PTT06*	1000	4000	24000
	PTT07*	1000	4000	24000
	PTT08*	1000	4000	24000
L ≥ 25mm	PTT03*	500	5000	25000
	PTT04*	500	5000	25000
	PTT05*	500	5000	25000
	PTT06*	200	4000	20000
	PTT07*	200	4000	20000
	PTT08*	200	4000	20000

Part No.	Withstanding Voltage	Resistance at 25 °C R _n	Maximum Current	Switching Temperature	Dimensions (mm)		
	(Vdc)	(Ω)	(A)	(°C)	D max.	T max.	d ± 0.02
PTT03S7151 ◇ *	600	150	0.3	70 ± 10	4.5	4.5	0.5
PTT03S7221 ◇ *		220					
PTT03S7331 ◇ *		330					
PTT03S7471 ◇ *		470					
PTT03 □ □ 681 ◇ *	900	680	0.3	50 ± 10 or 70 ± 10			
PTT03 □ □ 102 ◇ *		1000					
PTT03 □ □ 152 ◇ *		1500					
PTT03 □ □ 222 ◇ *		2200					
PTT03 □ □ 332 ◇ *		3300					

Part No.	Withstanding Voltage	Resistance at 25°C R _n	Maximum Current	Switching Temperature	Dimensions (mm)							
	(Vdc)	(Ω)	(A)	(°C)	D max.	T max.	d ± 0.02					
PTT04□□101◇*	700	100	0.4	50 ± 10 or 70 ± 10	5.5	5.2	0.6					
PTT04□□151◇*		150										
PTT04□□221◇*	800	220										
PTT04□□331◇*	900	330										
PTT04□□471◇*		470										
PTT04□□681◇*	1000	680										
PTT04□□102◇*		1000										
PTT04□□152◇*		1500										
PTT04□□222◇*		2200										
PTT04□□332◇*	1000	3300										
PTT04□□472◇*		4700										
PTT04B0101◇*	600	100	0.4	100 ± 10								
PTT04B0151◇*		150										
PTT04B0221◇*	700	220										
PTT04B0331◇*		330										
PTT04B0471◇*	800	470										
PTT04B0681◇*	900	680										
PTT04B0102◇*		1000										
PTT04B0152◇*		1500										
PTT05□□101◇*		800						100	0.6	50 ± 10 or 70 ± 10		
PTT05□□151◇*	900	150										
PTT05□□221◇*		220										
PTT05B0101◇*	700	100	0.6	100 ± 10	6.5	5.5	0.6					
PTT05B0151◇*		150										
PTT05B0221◇*	800	220										
PTT05B0331◇*		330										
PTT05B0471◇*	900	470										
PTT05B0681◇*		680										
PTT05B0102◇*		1000										
PTT05B0152◇*		1500										
PTT07B0101◇*	800	100						0.9	100 ± 10	8.5	5.5	0.6
PTT07B0151◇*		150										
PTT07B021◇*	900	220										
PTT07B0331◇*		330										
PTT07B0471◇*		470										
PTT07B0681◇*		680										
PTT07B0102◇*		1000										

Note: 1. □ means Switching Temperature

2. ◇ means Resistance Tolerance

3. * means Packaging(B=Bulk or T=Taping)

Overload Protection Series

Product No.: PTC*

Features:

- ◆ ROHS compliant
- ◆ Low resistance, small size
- ◆ Stable over a long time
- ◆ Operation temperature range: 0 ~ +60 °C(V=Vmax), -25 ~ +125 °C(V=0)

Applications:

- ◆ Home appliance
- ◆ Electrical equipment(Electrical machinery, transformer,electric meter)

Part Number Code

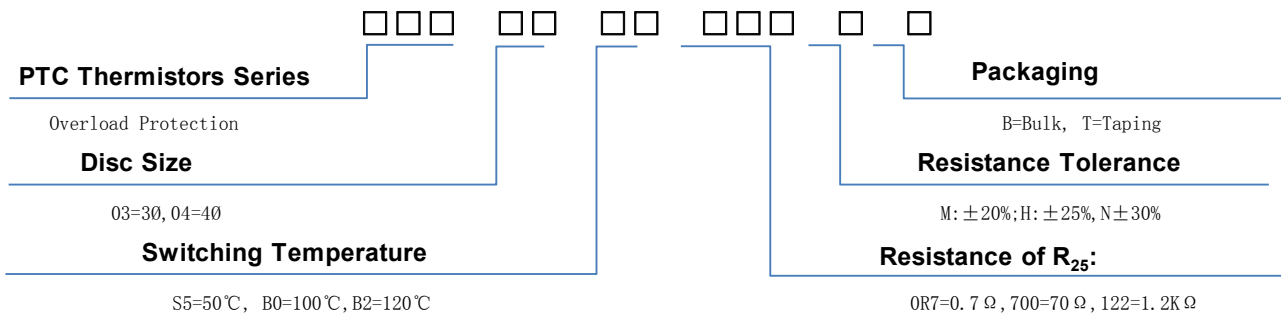

Structure and Dimensions

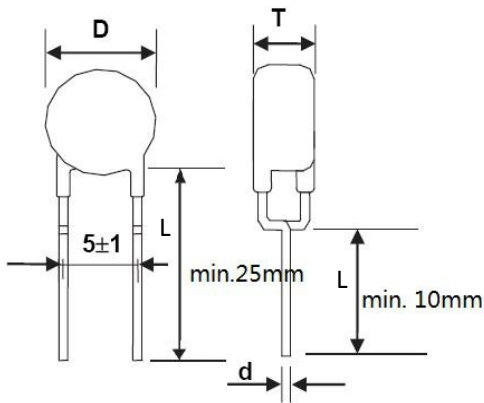

Packing:

L	Part No.	Quantity (pcs)		
		bag	box (small)	box (big)
L ≤ 10mm	PTC03*	1000	10000	50000
	PTC05*	1000	10000	50000
	PTC08*	500	4000	24000
	PTC10*	250	1500	12000
	PTC13*	200	600	5000
	PTC15*	150	600	5000
	PTC20*	150	450	4500
	PTC25*	50	250	3250
L ≥ 25mm	PTC03*	500	5000	25000
	PTC05*	500	5000	25000
	PTC08*	200	4000	16000
	PTC10*	200	1000	10000
	PTC13*	100	400	5000
	PTC15*	100	400	5000
	PTC20*	100	300	3000
	PTC25*	50	200	3000

Part No.	Max. Voltage	Rated current	Switching Current	Maximum Current	Resistance at 25°C	Switching Temperature	Dimensions (mm)		
	(V)	(mA)	(mA)	(A)	Rn (Ω)	(°C)	Dmax	Tmax	d±0.02
PTC10B21R2◇*	30	600	1200	4	1.2	120	11	4.2	0.6
PTC08B21R8◇*		450	900	2.9	1.8		9	4	0.6
PTC05B24R6◇*		250	500	1	4.6		6.5	4	0.6
PTC03B2130◇*		120	240	0.5	13		4	4	0.5

Part No.	Max. Voltage	Rated current	Switching Current	Maximum Current	Resistance at 25°C	Switching Temperature	Dimensions (mm)			
	(V)	(mA)	(mA)	(A)	Rn (Ω)	(°C)	Dmax	Tmax	d±0.02	
PTC20S81R7◇*	80	340	700	10	1.7	80	23	4.2	0.6	
PTC15S82R3◇*		245	500	8	2.3		18.5	4.2	0.6	
PTC13S83R7◇*		170	350	5	3.7		14.5	4	0.6	
PTC10S85R6◇*		130	265	4	5.6		12	4	0.6	
PTC08S89R4◇*		90	190	3	9.4		10	4	0.6	
PTC05S8250◇*		50	110	1	25		7.5	4	0.6	
PTC03S8550◇*		30	60	0.7	55		5	4	0.5	
PTC20B21R7◇*		700	1400	10	1.7		120	23	4.2	0.6
PTC15B22R3◇*		450	900	8	2.3	18.5		4.2	0.6	
PTC13B23R7◇*		320	640	5.5	3.7	14.5		4	0.6	
PTC10B25R6◇*		250	500	4	5.6	12		4	0.6	
PTC08B29R4◇*		150	300	3	9.4	10		4	0.6	
PTC05B2250◇*		85	170	1	25	7.5		4	0.6	
PTC03B2550◇*		50	100	0.7	55	5		4	0.5	
PTC25S82R6◇*		265	350	710	10	2.6		80	27	5.5
PTC20S83R7◇*			250	510	7	3.7	23		5.5	0.6
PTC15S86R0◇*	170		350	4	6	18.5	5.5		0.6	
PTC13S8100◇*	110		230	2.2	10	14.5	5.5		0.6	
PTC10S8150◇*	90		180	1.5	15	12	5.3		0.6	
PTC08S8250◇*	60		130	1	25	10	5.3		0.6	
PTC05S8700◇*	30		70	0.4	70	7.5	5.3		0.6	
PTC03S8151◇*	15		40	0.2	150	5	5		0.5	
PTC25B22R6◇*	650		1300	10	2.6	120	27	5.5	0.6	
PTC20B23R7◇*	460		920	7	3.7		23	5.5	0.6	
PTC15B26R0◇*	330		660	4	6		18.5	5.5	0.6	
PTC13B2100◇*	200		400	2.2	10		14.5	5.5	0.6	
PTC10B2150◇*	140		280	1.5	15		12	5.3	0.6	
PTC08B2250◇*	100		200	1	25		10	5.3	0.6	
PTC08B2350◇*	80		160	1	35		10	5.3	0.6	
PTC08B2450◇*	70		140	1	45		10	5.3	0.6	
PTC08B2550◇*	60	125	1	55	10		5.3	0.6		
PTC08B2650◇*	55	110	1	65	10		5.3	0.6		
PTC05B2700◇*	50	100	0.4	70	7.5		5.3	0.6		
PTC05B2121◇*	35	70	0.4	120	7.5		5.3	0.6		
PTC03B2151◇*	30	60	0.2	150	5		5	0.5		
PTC08B2700◇*	420	65	135	1	70		9.5	7	0.6	
PTC08B2121◇*		50	110	1.1	120		9.5	7	0.6	
PTC08B2151◇*		43	86	1.1	150		9.5	7	0.6	
PTC05B2601◇*		21	39	0.2	600	7.5	5.3	0.6		
PTC05B1122◇*	550	15	30	0.1	1200	110	7.5	5.3	0.6	
PTC05B1152◇*		12	24	0.1	1500		7.5	5.3	0.6	
PTC08B2501◇*		24	48	0.8	500	120	9.5	7	0.6	
PTC03B0162◇*	600	10	20	0.5	1600	100	5.5	4.5	0.5	
PTC05B0401◇*		10	50	0.8	400		7	5.5	0.6	

Note: 1. ◇ means Resistance Tolerance

2. * means Packaging(B=Bulk or T=Taping)

PTC Thermistors as Limit Temperature Sensors

Product No.: PTM*

Features:

- ◆ RoHS Compatible
- ◆ Low-resistance type, steep R/T cu .
- ◆ Color coding of litz wires to DIN44081.
- ◆ Thermistor pellet with insulating encapsulation .
- ◆ Silver-plated and PTFE-insulated AWG26 litz wires .
- ◆ Extremely fast response due to small dimensions
- ◆ Characteristics for sensing temperatures $T_{sense}=90$ up to 160°C conform with DIN44081 .

Applications:

- ◆ Transformer
- ◆ Motor protector
- ◆ Motor temperature control
- ◆ Limit temperature monitoring
- ◆ Thermal protection of winding in electric motors

Technical base data

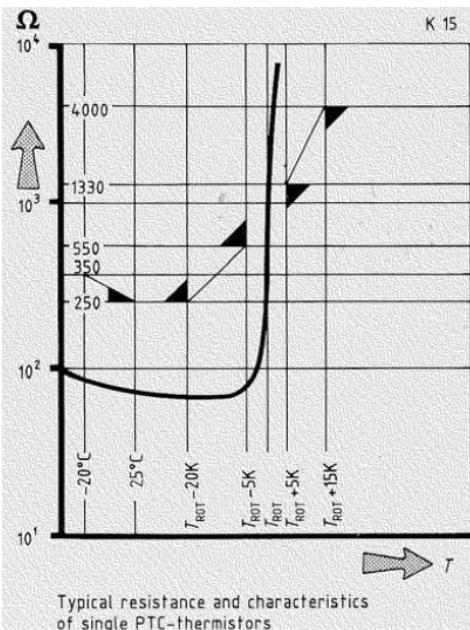

Typical resistance - temperature characteristic

The advantage of PTC - thermistors is demonstrated by the very steep curve as shown in the graph. This graph shows the relationship between temperature and resistance. The characteristic of the curve demonstrates the accuracy of the PTC's. The increase in the resistance from the switching point onwards is exponential. The DIN - standards relevant to these products cover the temperature range from $+60^{\circ}\text{C}$ to $+180^{\circ}\text{C}$ and are DIN 55081 and 44082.

Resistance values (according to DIN44081 and DIN44082)

The resistance temperature characteristic of PTC thermistors for the thermic protection of machines is defined by the following formula:

Temperature range T_{KL}	PTC resistance R_{KL}	Measuring DC voltage U (test voltage)
-20°C to $T_{ROT} - 20\text{K}$	$R_{KL} < 250 \Omega$	$U < 2.5\text{V}$
at $T_{ROT} - 5\text{K}$	$R_{KL} < 550 \Omega$	$U < 2.5\text{V}$
at $T_{ROT} + 5\text{K}$	$R_{KL} \geq 1330 \Omega$	$U < 2.5\text{V}$
at $T_{ROT} + 15\text{K}$	$R_{KL} \geq 4000 \Omega$	$U < 7.5\text{V}$

Load must not be applied to the thermistors as this creates a self heating effect.

At ambient temperature the resistance value of thermistors is normally between 50 ohm and 100 ohm. it can also be between 30 and 250 ohm. At ambient temperature the resistance values have no relevance to the serviceability (functionality) at the ROT (rated operating temperature).

The ROT of PTC thermistors in the range of $+60^{\circ}\text{C}$ to $+180^{\circ}\text{C}$ progresses normally in steps of 10K.

Application example for electric motor and machine protection.

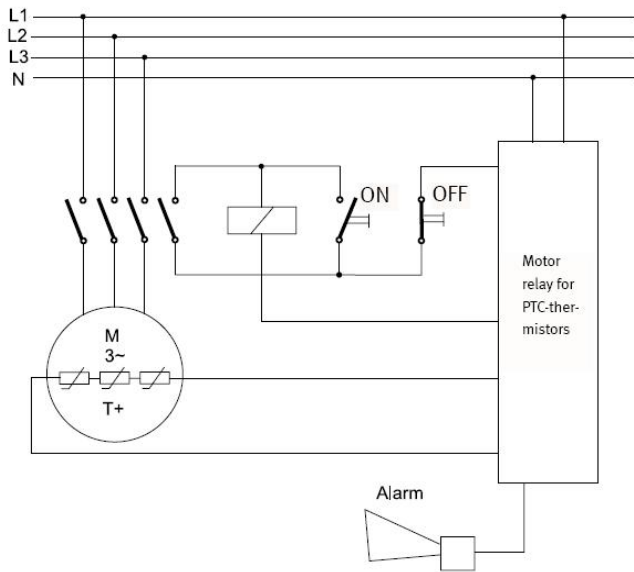

The accurate sensitivity and small dimensions of PTC's makes them ideal for all electrical machine protection applications. For electric motor or transformer protection the PTC must be placed within the windings. The ROT (rated operating temperature) is chosen in relation to the insulation class of the windings. Three phase motors will require 3 PTC Thermistors, wired in series. The terminal leads of the PTC must be connected through a terminal block to a relay and cut off device (Schutz). When the temperature of the motor exceeds ROT the relay is activated and triggers the power cut off. When the temperature of the windings cools to below ROT the low resistance of the PTC thermistor will allow the motor(transformer) to be re started.

PTC operational range for use with control relays for temperature protection

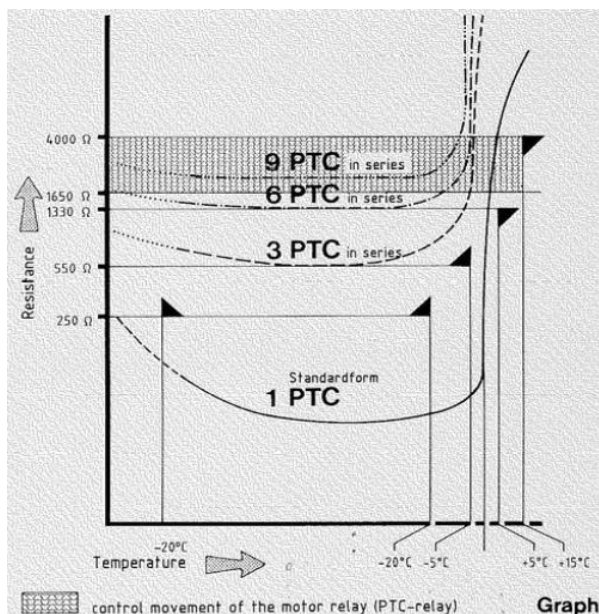

Control relays trip normally between 1650 Ω and 4000 Ω (according to DIN VDE 0660)

Switching points for 1, 3, 6 and 9 PTC thermistors connected in series is shown in the diagram:

- ∴ 1 PTC switches no later than $T_{ROT} + 15K$, no earlier than $T_{ROT} + 5K$.
- ∴ 3 PTC switch no later than $T_{ROT} + 5K$, no earlier than $T_{ROT} - 5K$.
- ∴ 6 PTC switch no later than T_{ROT} , no earlier than $T_{ROT} - 20K$.
- ∴ 9 PTC at ambient temperature have a combined resistance value which is automatically within the switching boundaries of the control relay.

Part Number Code

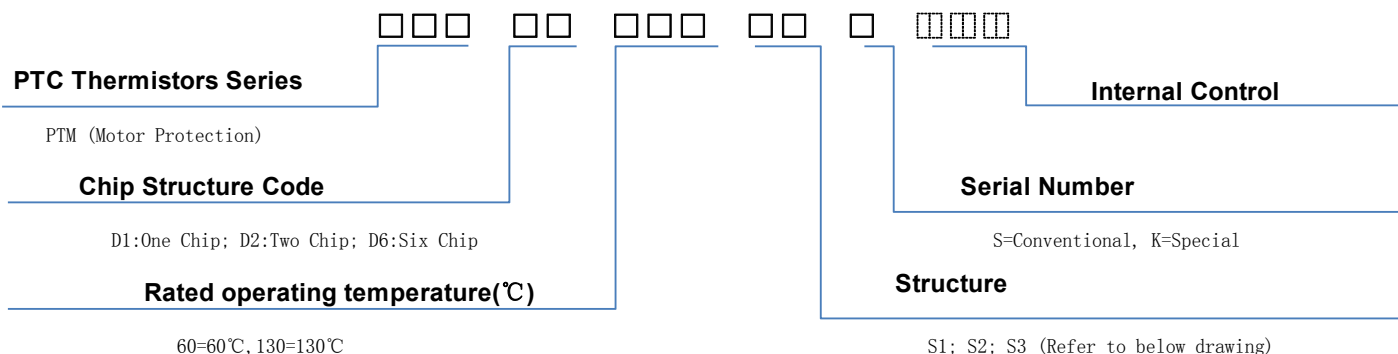

Structure and Dimensions

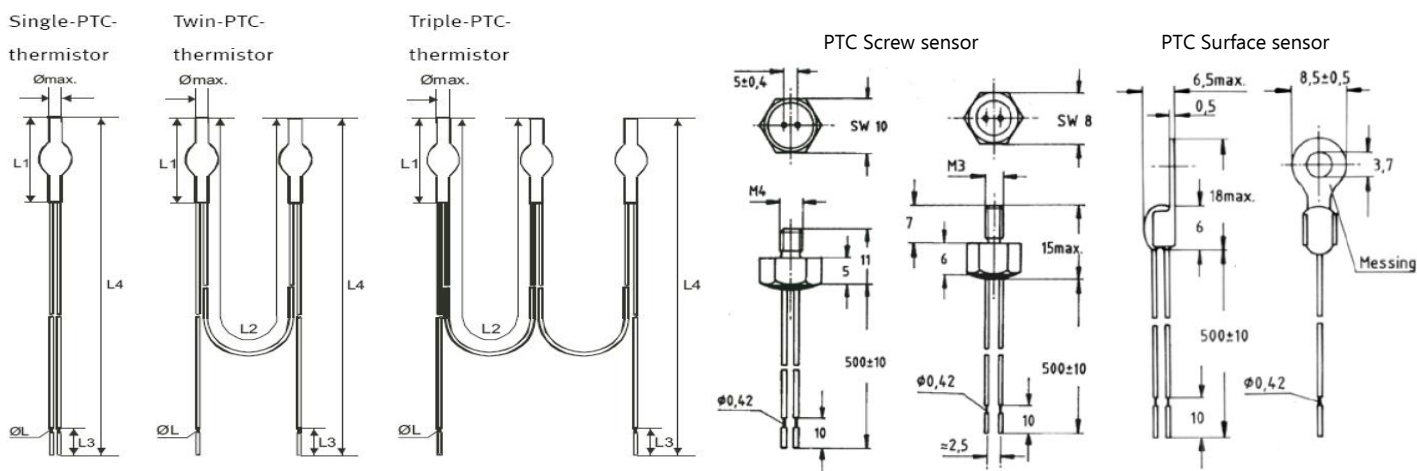

PTC-model	L1	L2	L3	L4	Φ max.	Φ L (according to choice of producer)
	(mm)	(mm)	(mm)	(mm)	(mm)	(mm)
standard	15	180	10	520	3.5	0.42 / 0.54
miniature	11	180	10	520	2.5	0.42 / 0.54

Legend: * Dimensions: other design and change of length of leads.

* L4 according to customer's requirements.

* Resistance value is given for single PTC thermistors, the value is to be multiplied for twin, triple and multiple sets.

Technical information and colour coding of leads for PTC thermistors

Rated operating temperature (°C)	±Tolerance $T_{ROT} \pm \Delta T_{ROT}$ (°C)	Resistance R (Ω) [®] from -20°C to $T_{ROT} - 20K$	Resistance R(Ω) [®] at PTC thermistor temperature:			Wire Color		
			$T_{ROT} - \Delta T_{ROT}$ ($U_{KL} \leq 2.5V$)	$T_{ROT} + \Delta T_{ROT}$ ($U_{KL} \leq 2.5V$)	$T_{ROT} + 15k$ ($U_{KL} \leq 7.5V$)			
30	±5	≤100				Brown/Black		
40						Brown/Red		
50						Brown/Gray		
60					≤570	≥570	-	White/Gray
70					≤570	≥570	-	White/Brown
80					≤570	≥570	-	White/White
90					≤550	≥1330	≥4000	Green/Green
100					≤550	≥1330	≥4000	Red/Red
105					≤550	≥1330	≥4000	Blue/Gray
110					≤550	≥1330	≥4000	Brown/Brown
115					≤550	≥1330	≥4000	Blue/Green
120					≤550	≥1330	≥4000	Gray/Gray
125					≤550	≥1330	≥4000	Red/Green
130					≤550	≥1330	≥4000	Blue/Blue
135					≤550	≥1330	≥4000	Red/Black
140					≤550	≥1330	≥4000	White/Blue
145					≤550	≥1330	≥4000	White/Black
150					≤550	≥1330	≥4000	Black/Black
155					≤550	≥1330	≥4000	Blue/Black
160					≤550	≥1330	≥4000	Blue/Red
165						Blue/Brown		
170	±7		≤570	≥570	-	White/Green		
180			≤570	≥570	-	White/Red		

Silicon Temperature Sensors

Product No.: KTY*

The temperature sensors in the LTP-KTY * series have a positive temperature coefficient of resistance and are suitable for use in measurement and control systems. The sensors are encapsulated in the SOD68 (DO-34) package.

Features:

- ◆ High accuracy and reliability
- ◆ Virtually linear characteristics
- ◆ Temperature range -40 Cel to +300 Cel
- ◆ Long-term stability
- ◆ Positive temperature coefficient; fail-safe behavior
- ◆ Nickel plated leads

Caution:

This device is sensitive to ElectroStatic Discharge (ESD). Therefore care should be taken during transport and handling.

* Other special selections are available on request.

Part Number Code

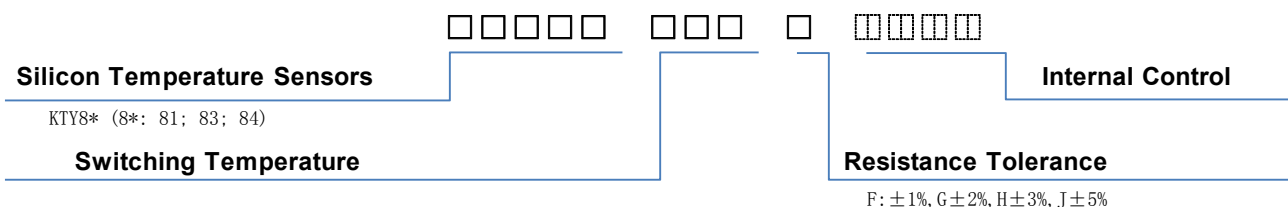

Structure and Dimensions

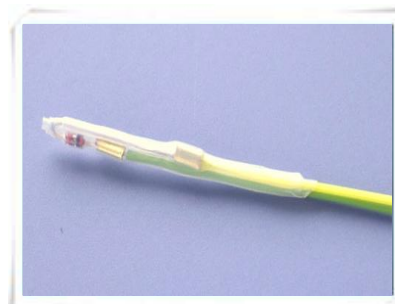
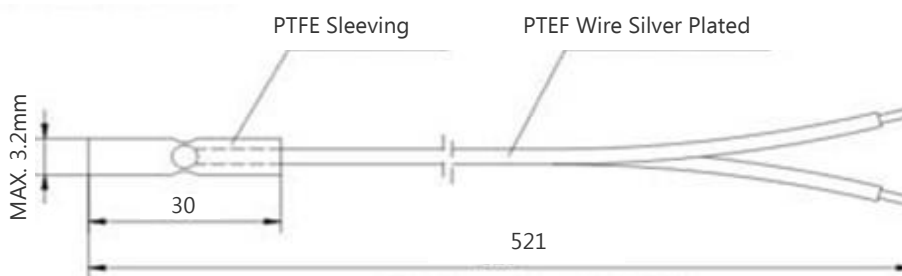
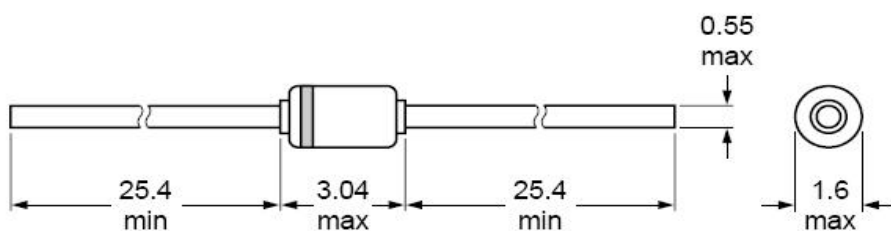

Resistance - Temperature Graph

KTY81 Series

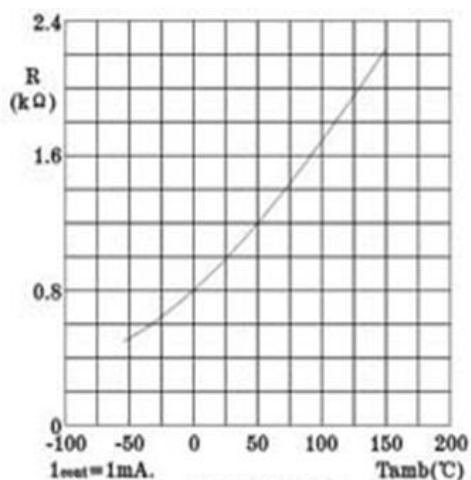

KTY83 Series

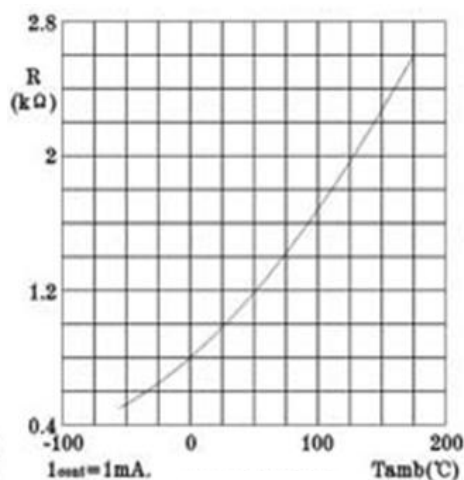

KTY84 Series

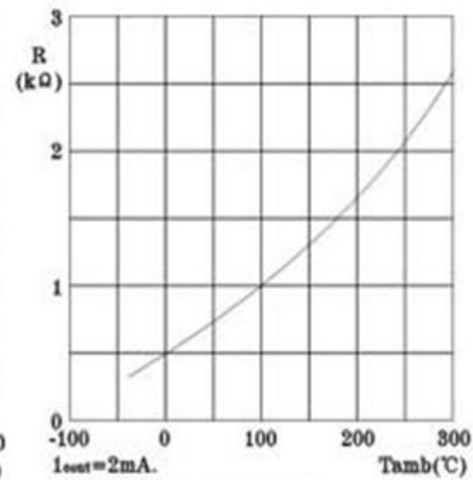

Model	Temperature Coefficient	Thermal time constant(τ)			Operating temperature
		In still air	In still liquid	In flowing liquid	
LPT-KTY81	0.79%K	30s	5s	3s	-55 ~ 150°C
LPT-KTY83	0.76%K	20s	1s	0.5s	-40 ~ 175°C
LPT-KTY84	0.61%K	20s	1s	0.5s	-40 ~ 300°C

Symbol	Model	Conditions	Min	Center	Max.	Unit	Resistance at25 °C
R ₂₅	LPT-KTY81/210	I _{sen(cont)} =1mA T _{amb} =25°C	1980		2020	Ω	2000
	LPT-KTY81/220		1960		2040	Ω	2000
	LPT-KTY81/221		1960		2000	Ω	1980
	LPT-KTY81/222		2000		2040	Ω	2020
	LPT-KTY81/250		1900		2100	Ω	2000
	LPT-KTY81/251		1900		2000	Ω	1950
	LPT-KTY81/252		2000		2100	Ω	2050
R ₂₅	LPT-KTY83/110	I _{sen(cont)} =1mA T _{amb} =25°C	990		1010	Ω	1000
	LPT-KTY83/121		980		1000	Ω	990
	LPT-KTY83/122		1000		1020	Ω	1010
	LPT-KTY83/151		950		1000	Ω	975
	LPT-KTY83/152		1000		1050	Ω	1025
R ₁₀₀	LPT-KTY84/130	I _{sen(cont)} =2mA T _{amb} =100°C	970	1000	1030	Ω	603
	LPT-KTY84/150		950	1000	1050	Ω	603
	LPT-KTY84/151		950	975	1000	Ω	603
	LPT-KTY84/152		1000	1025	1050	Ω	600



- ◆ NTC SMD Thermistor
- ◆ NTC CHIP Thermistor (Film Type and Diode Type)
- ◆ NTC Power Thermistor
- ◆ NTC Thermistor Sensors
- ◆ PTC Thermistor
- ◆ PTC SMD Thermistor
- ◆ PTC Temperature Sensors
- ◆ PTC Limit Temperature Sensors
- ◆ PTC Silicon Temperature Sensors
- ◆ Varistors
- ◆ Thermally Protected Varistor (TMOV)
- ◆ Disc/Block Type Varistor For Lightning Protection (MOV)
- ◆ Fuse

Dongguan Wuge Electronics Technology Co., Ltd.

ADD:

Plant (1): No. 53, Yayuan Road, 4th Village, Shijie Town, Dongguan City, Guangdong Province, P.R.China

Postal

codes: 526000

Plant (2): No.23, Construction II Road, Duanzhou Area, Zhaoqing City, Guangdong Province, P.R.China

Postal

codes: 523290

TEL: 86-769-86309511 FAX: 86-769-8637 0800

Jackcon (HK) Industrial Limited

ADD: Unit 04, 7/F, Bright Way Tower, No.33, Mongkok Road, Kowloon, Hongkong

TEL: +852-27935511 FAX: +852-35902333

Website: <http://www.RTsensor.com>

E-Mail: rtsensor@rtsensor.com, sales1@rtsensor.com, sales2@rtsensor.com